



Standard Specification for Mechanical Seals for Shipboard Pump Applications¹

This standard is issued under the fixed designation F 1511; the number immediately following the designation indicates the year of original adoption or, in the case of revision, the year of last revision. A number in parentheses indicates the year of last reapproval. A superscript epsilon (ϵ) indicates an editorial change since the last revision or reapproval.

1. Scope

1.1 This specification covers mechanical end-face seals for centrifugal and positive displacement pumps for shipboard use.

1.2 The following types of seals are not included in this specification: lip seals, oil seals, circumferential seals, or labyrinth seals.

1.3 The values stated in inch-pound units are to be regarded as standard. The values given in parentheses are mathematical conversions to SI units that are provided for information only and are not considered standard. A companion hard metric standard is in the process of preparation.

1.4 Special requirements for U.S. Navy Shipboard Pump Applications are included in Supplement S1.

2. Referenced Documents

2.1 ASTM Standards:²

A 108 Specification for Steel Bar, Carbon and Alloy, Cold-Finished

A 182/A 182M Specification for Forged or Rolled Alloy and Stainless Steel Pipe Flanges, Forged Fittings, and Valves and Parts for High-Temperature Service

A 240/A 240M Specification for Chromium and Chromium-Nickel Stainless Steel Plate, Sheet, and Strip for Pressure Vessels and for General Applications

A 276 Specification for Stainless Steel Bars and Shapes

A 313/A 313M Specification for Stainless Steel Spring Wire

A 351/A 351M Specification for Castings, Austenitic, for Pressure-Containing Parts

A 436 Specification for Austenitic Gray Iron Castings

A 494/A 494M Specification for Castings, Nickel and Nickel Alloy

A 564/A 564M Specification for Hot-Rolled and Cold-Finished Age-Hardening Stainless Steel Bars and Shapes

A 579/A 579M Specification for Superstrength Alloy Steel Forgings

A 693 Specification for Precipitation-Hardening Stainless and Heat-Resisting Steel Plate, Sheet, and Strip

A 744/A 744M Specification for Castings, Iron-Chromium-Nickel, Corrosion Resistant, for Severe Service

B 62 Specification for Composition Bronze or Ounce Metal Castings

B 127 Specification for Nickel-Copper Alloy (UNS N04400) Plate, Sheet, and Strip

B 164 Specification for Nickel-Copper Alloy Rod, Bar, and Wire

B 166 Specification for Nickel-Chromium-Iron Alloys (UNS N06600, N06601, N06603, N06690, N06693, N06025, and N06045)* and Nickel-Chromium-Cobalt-Molybdenum Alloy (UNS N06617) Rod, Bar, and Wire

B 168 Specification Nickel-Chromium-Iron Alloys (UNS N06600, N06601, N06603, N06690, N06693, N06025, and N06045) and Nickel-Chromium-Cobalt-Molybdenum Alloy (UNS N06617) Plate, Sheet, and Strip

B 271 Specification for Copper-Base Alloy Centrifugal Castings

B 333 Specification for Nickel-Molybdenum Alloy Plate, Sheet, and Strip

B 335 Specification for Nickel-Molybdenum Alloy Rod

B 338 Specification for Seamless and Welded Titanium and Titanium Alloy Tubes for Condensers and Heat Exchangers

B 348 Specification for Titanium and Titanium Alloy Bars and Billets

B 367 Specification for Titanium and Titanium Alloy Castings

B 443 Specification for Nickel-Chromium-Molybdenum-Columbium Alloy (UNSN06625) and Nickel-Chromium-Molybdenum-Silicon Alloy (UNS N06219)* Plate, Sheet, and Strip

B 446 Specification for Nickel-Chromium-Molybdenum-Columbium Alloy (UNS N06625), Nickel-Chromium-Molybdenum-Silicon Alloy (UNS N06219), and Nickel-Chromium-Molybdenum-Tungsten Alloy (UNS N06650)* Rod and Bar

B 472 Specification for Nickel Alloy Billets and Bars for Reforging

¹ This specification is under the jurisdiction of ASTM Committee F25 on Ships and Marine Technology and is the direct responsibility of Subcommittee F25.11 on Machinery and Piping Systems.

Current edition approved May 1, 2006. Published May 2006. Originally approved in 1994. Last previous edition approved in 2005 as F 1511 – 05.

² For referenced ASTM standards, visit the ASTM website, www.astm.org, or contact ASTM Customer Service at service@astm.org. For *Annual Book of ASTM Standards* volume information, refer to the standard's Document Summary page on the ASTM website.

- B 473** Specification for UNS N08020, UNS N08024, and UNS N08026 Nickel Alloy Bar and Wire
- B 505/B 505M** Specification for Copper Alloy Continuous Castings
- B 584** Specification for Copper Alloy Sand Castings for General Applications
- B 637** Specification for Precipitation-Hardening Nickel Alloy Bars, Forgings, and Forging Stock for High-Temperature Service
- B 670** Specification for Precipitation-Hardening Nickel Alloy (UNS N07718) Plate, Sheet, and Strip for High-Temperature Service
- D 1141** Practice for the Preparation of Substitute Ocean Water
- D 1418** Practice for Rubber and Rubber Latices—Nomenclature
- D 3294** Specification for Polytetrafluoroethylene (PTFE) Resin Molded Sheet and Molded Basic Shapes
- D 3951** Practice for Commercial Packaging
- 2.2 *ASQ Standards:*³
- ASQC Z1.4** American Society of Quality, Quality Conformance Inspection
- 2.3 *ANSI Standards:*⁴
- ANSI Y14.1** Drawing Sheet Size and Format
- ANSI Y14.2** Line Convention and Lettering
- ANSI Y14.3** Multi and Sectional View Drawings
- ANSI Y14.5** Dimensioning and Tolerancing for Engineering Drawings
- ANSI Y14.6** Screw Thread Representation
- ANSI Y14.26.3** Computer-Aided Preparation of Production Definition Data, Terms and Definitions
- 2.4 *Military Standards:*⁵
- MIL-S-901** Shock Tests, H.I. (High Impact); Shipboard Machinery, Equipment & Systems, Requirements for
- MIL-P-16789** Packaging of Pumps, Including Prime Movers and Associated Repair Parts
- MIL-R-83248** Rubber Fluorocarbon Elastomer, High Temperature, Fluid, and Compression Set Resistant
- MIL-STD-167-1** Environmental Vibration Testing

2.5 *ISO Standard:*⁴

ISO 9001 Quality Systems—Model for Quality Assurance in Design/Development, Production, Installation, and Service

2.6 *Other Document:*⁵

Metals and Alloys, Unified Numbering System-DS-56f

3. Terminology

3.1 Refer to **Annex A1** for terminology relating to mechanical seals.

4. Classification of Seal Arrangements

4.1 For this specification, mechanical seals shall be classified by type, grade, and class. The categories are divided by application arrangement in the equipment in which it is installed:

4.1.1 Type A—Inside Single Mounted Seals

4.1.2 Type B—Outside Single Mounted Seals

4.1.3 Type C—Double Seals

4.1.4 Type D—Tandem Seals

4.1.5 Type E—Gas Seals

4.1.6 Type F—Special Arrangements/Applications Vacuum or Gas Seal

4.1.7 Grade 1—Basic End Face Seal

4.1.8 Grade 2—Cartridge Seal

4.1.9 Grade 3—Split Seal

4.1.10 Class 0—Nonsplit Seal Assembly

4.1.11 Class 1—Partial Split Seal Assembly, Solid Gland

4.1.12 Class 2—Partial Split Seal Assembly, Split Gland

4.1.13 Class 3—Fully Split Seal Assembly, Solid Gland

4.1.14 Class 4—Fully Split Seal Assembly, Split Gland

4.2 **Figs. 1-6** give general orientation information for various types of seals. The specific design of seal shown is not limited to that particular application.

5. Ordering Information

5.1 The purchaser (buyer) shall provide the manufacturer with all of the pertinent application data shown in **Figs. 7-9**. If special operating conditions exist that are not shown in the checklist, they shall also be described.

6. Material

6.1 Mechanical seals shall be constructed of materials selected from **Tables 1-3** after reviewing temperature, pressure/velocity (PV), and corrosion resistance requirements for all parts for each application.

6.2 *Metal Components:*

³ Available from American Society for Quality (ASQ), 600 N. Plankinton Ave., Milwaukee, WI 53203.

⁴ Available from American National Standards Institute, 25 W. 43rd St., 4th Floor, New York, NY 10036.

⁵ Available from Standardization Documents Order Desk, Bldg. 4, Section D, 700 Robbins Ave., Philadelphia, PA 19111-5098, Attn: NPODS.

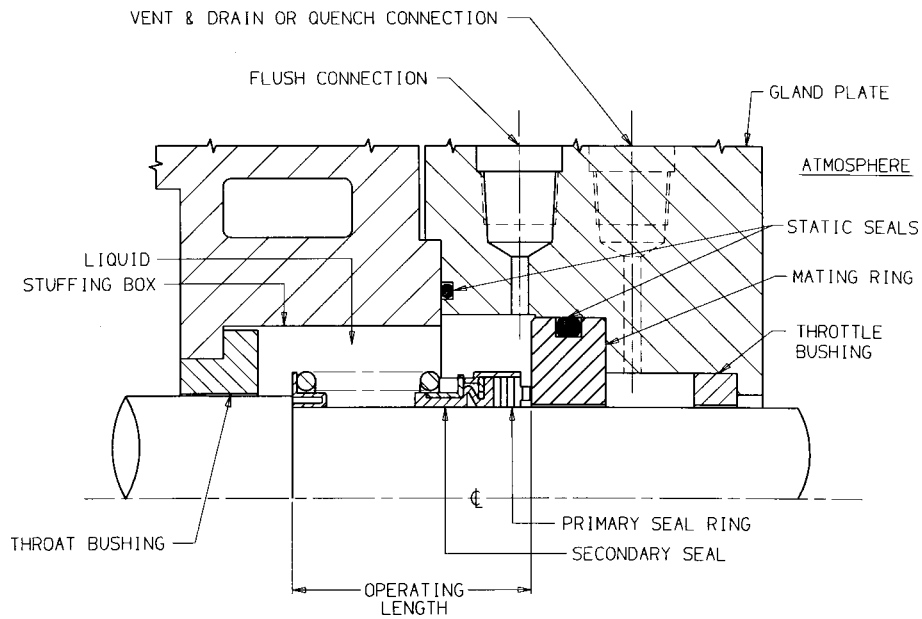

FIG. 1 Single Seal—Inside Bellows Secondary Seal, Classification Type A Grade 1

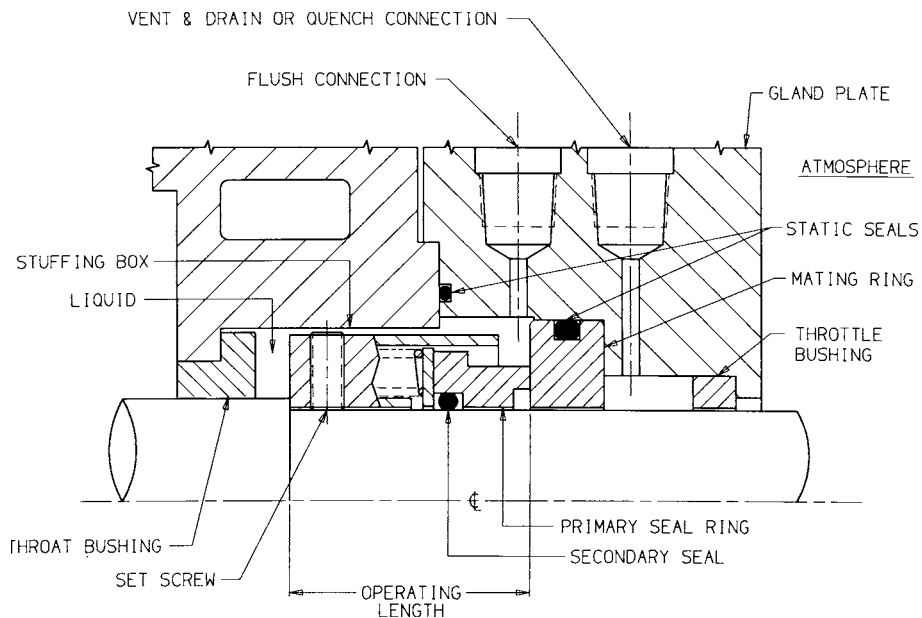

FIG. 2 Single Seal—Inside O-Ring Secondary Seal, Classification Type A Grade 1

6.2.1 Mechanical seal metal parts in contact with the pumped liquid shall be compatible with their environment.

6.2.2 Table 1 identifies metal component compatibility.

6.2.3 Material specifications:

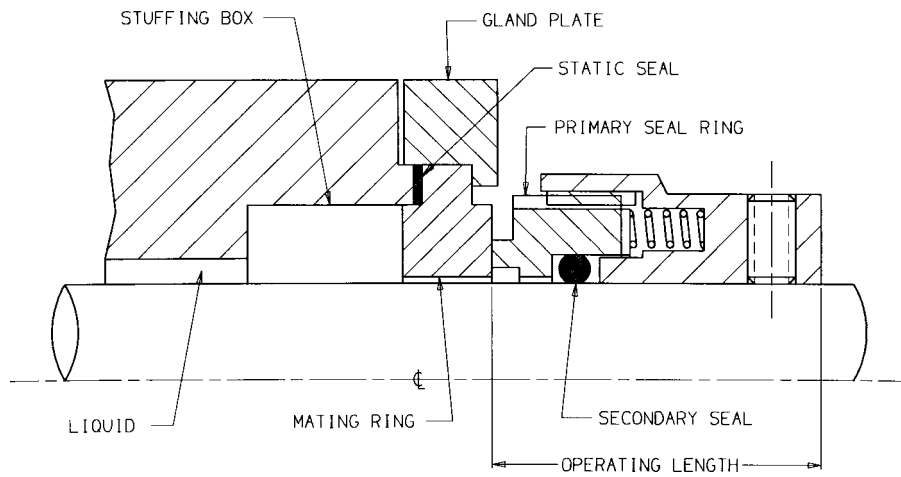

FIG. 3 Single Seal—Outside Mounted Classification Type B Grade 1

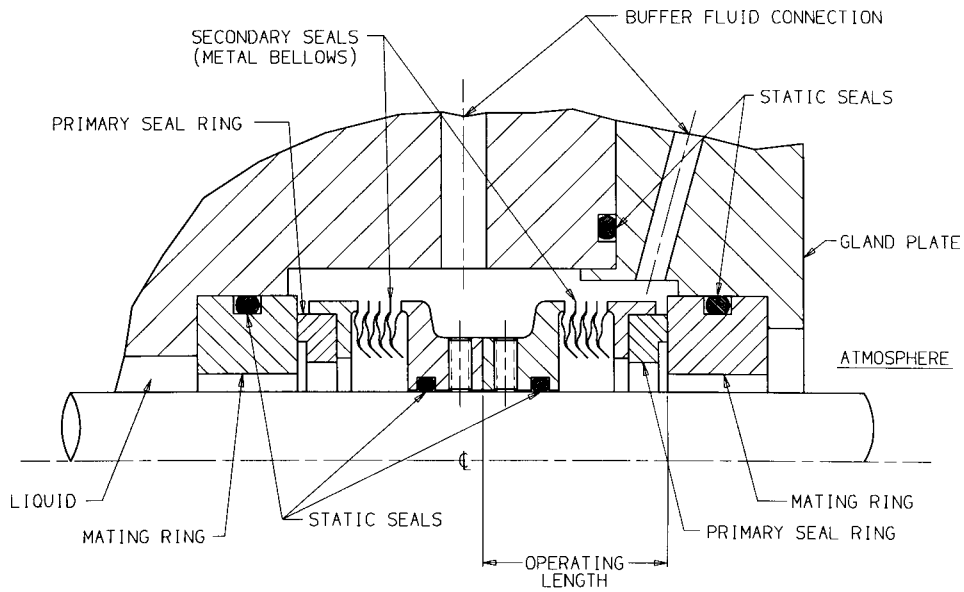

FIG. 4 Double Seals—Back to Back Classification Type C Grade 1

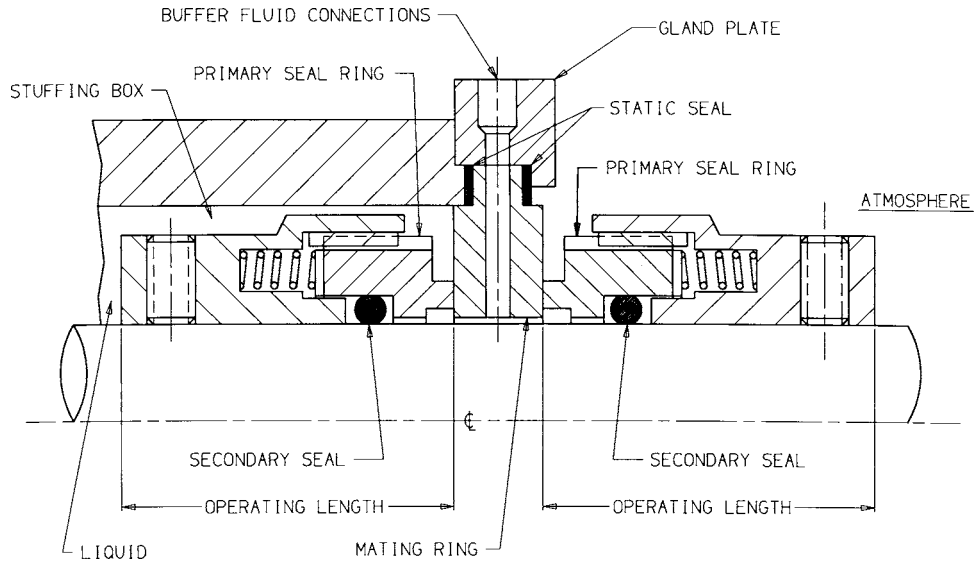

FIG. 5 Double Seals—Face to Face Classification Type C Grade 1

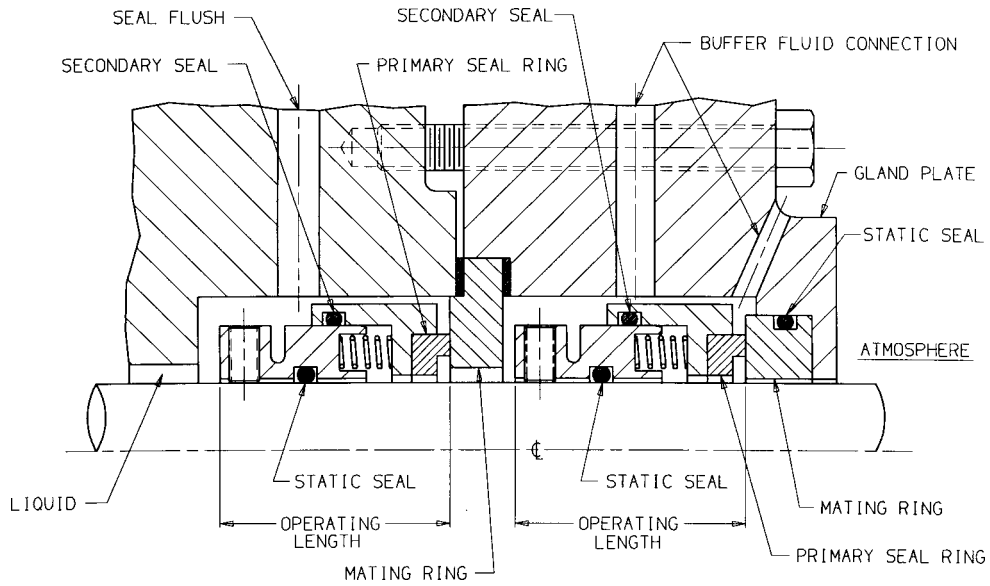

FIG. 6 Tandem Seals Classification Type D Grade 1

1.1 *Seal Description*
 Type _____ Grade _____

1.2 *Pump Description*
 Pump Mfg. _____ Model _____ Size _____
 Pump S/N _____
 Pump Type (Horizontal, Vertical, etc.) _____
 No. of Stages _____
 Sleeve or Shaft Mat'l _____ Casting Mat'l _____
 Cooling Water Available? _____ °F _____ GPM
 Stuffing Box Water Jacketed? Yes _____ No _____
 Is Face of Stuffing Box Machined? Yes _____ No _____

FILL OUT STUFFING BOX DIMENSIONS SHOWN ON FIG. 8

2.1 *Liquid Pumped*
 Fluid _____ Concentration _____ Specify for unique cargo pump fluid application
 Pumping Temperature (°F) Normal _____
 Max _____
 Min _____
 Specific Gravity at Operating Condition _____
 Viscosity Range at Operating Conditions/Temp. _____ SSU
 Vapor Pressure at Operating Conditions/Pressure _____ psig
 Corrosion/Erosion Caused by: _____ % Solids
 Abrasive Separator To be Supplied—Yes _____ No _____

2.2 *Operating Conditions*
 Rated Discharge Pressure Max (psig) _____
 Suction Box Pressure Range (psig) _____
 Stuffing Box Pressure Range (psig) _____
 Stuffing Box Temperature Max (°F) _____
 Hydrostatic Test Pressure (psig) _____
 Speed (rpm) _____
 Direction of Rotation From Drive End CW or CCW _____

3.1 *Preservation and Packaging*
 Special Preservation & Packaging for Storage & Shipment _____
 Special Marking _____

4.1 *Other Special Requirements*
 Seal Manufacturer's Certification of Compliance Required—Yes _____ No _____

5.1 *US Navy Application Requirements*
 Supplement S1, ----- Yes _____ No _____
 Check applicable dimensional Table below:
 Table No. S1, Standard Long Mechanical Seal _____
 Table No. S2, Standard Short Mechanical Seal _____
 Table No. S3, Special Cartridge Seals Grade 2 _____
 Table No. S4, Special Seals Grade 1 _____

FIG. 7 Ordering Data Checklist

Material	ASTM
Copper alloy	B 271, B 584, B 505
Bronze	B 62
Alloy 20	B 472 and B 473 (UNS N08020, N08026)
316 stainless steel	A 240/A 240M, A 276, and A 313/A 313M (UNS S316XX)
304 stainless steel	A 182/A 182M, A 313/A 313M (UNS S304XX), A 351/A 351M (CF3, 3A; CF8, 8A; CF8C; CF10)
Alloyed stainless steel (cast)	A 744/A 744M (CN-7M, CN-7MS)
17-4 PH	A 564/A 564M and A 693 (UNS S17400)
AM 350	A 579 (Grade 61)
NiCu ^A	B 164 (UNS N04400, N04405), B 127, A 494/A 494M (Grades M35-1, M35-2, M-30H, M-25S)
NiMo	A 494/A 494M (Grades CW-2M, N-12 MV)
NiMo ^B (Alloy B)	B 333 and B 335 (UNS N10001, N10665, N10675)
NiCrFe ^C NiCrMoCo	B 166, B 168
NiCr	B 637, B 670
NiCrMoCb ^D	B 443, B 446
Steel	A 108
Austenitic grey iron	A 436
Titanium	B 338, B 348, B 367
Nickel cast iron (ductile nodular or graphitic)	A 436 Type 1

^A Monel[®] or equivalent has been found satisfactory for this purpose.

^B Hastelloy B or equivalent has been found satisfactory for this purpose.

^C Inconel X750⁷ or equivalent has been found satisfactory for this purpose.

^D Inconel 625⁷ or equivalent has been found satisfactory for this purpose.

6.3 *Face Materials*—Mechanical seal-wearing faces shall be selected to provide the desired performance and corrosion resistance for the specified design life of the seal.

6.3.1 Performance ranges for face combinations are listed in Table 2.

6.3.2 Face materials shall be of solid construction only; no overlays, deposited coatings, or sprayed on coatings are permitted.

6.3.3 Carbon is preferred for one of the faces unless the service is abrasive, dirty, or chemically active.

6.3.4 For special service requirements, hard on hard seal face combinations may be required. Face material combinations, such as silicon carbide versus silicon carbide, silicon carbide versus tungsten carbide, and tungsten carbide versus tungsten carbide, may be used as similar or dissimilar contacting face materials when recommended by the supplier and approved by the user.

6.4 *Face Material Specifications:*

6.4.1 *Carbon*—Suitable for service as recommended by the manufacturer. A carbon seal grade is a material having carbonaceous filler system comprised of pitch and resins, compacted and baked to a final temperature. These grades are subsequently impregnated with resin until they become impervious. All available carbons may not be suitable for a particular application. Carbons considered for use in a particular application shall be checked for suitability in accordance with the requirements of this specification.

6.4.2 *Tungsten Carbide*—6 to 10 % nickel or cobalt-bound solid tungsten carbide.

6.4.3 *Ceramic*—99.5 % minimum alumina ceramic suitable for the service as recommended by the manufacturer.

6.4.4 *Silicon Carbide*—(a) *Reaction-Bonded*—Solid fine-grained reaction-bonded silicon carbide 8 to 12 % free silicon, essentially free of carbon, impervious structure requiring no impregnant. (b) *Reaction-Bonded With Graphite*—A composite material of fine-grain reaction-bonded silicon carbide; 5 to 10 % free silicon and 10 to 30 % graphite; impervious structure requiring no impregnant. (c) *Direct Sintered*—Solid homogeneous silicon carbide essentially free of silicon and carbon, impervious structure requiring no impregnant. (d) *Direct Sintered Silicon Carbide*—Contains 10 % free graphite. (e) *Siliconized Carbon Graphite*—Approximately 0.025-in. (0.64-mm) thick conversion of silicon carbide on carbon substructure and impregnated with thermosetting resin.

6.5 *Elastomeric Materials:*

6.5.1 Special care should be given to the selection and installation of elastomeric components, such as bellows and O-rings. One of the most important considerations for elastomers is fluid compatibility. Table 3 references most shipboard applications. Consult the seal manufacturer for fluids not listed.

6.5.2 *Material Classification/Specification:*

6.5.2.1 *Nitrile*—Practice D 1418, Class Designation NBR.

⁶ The term “Monel” and the Monel logo are trademarks of the Special Metals Corporation, Huntington, WV, USA.

⁷ The term “Inconel” and the Inconel logo are trademarks of the Special Metals Corporation, Huntington, WV, USA.

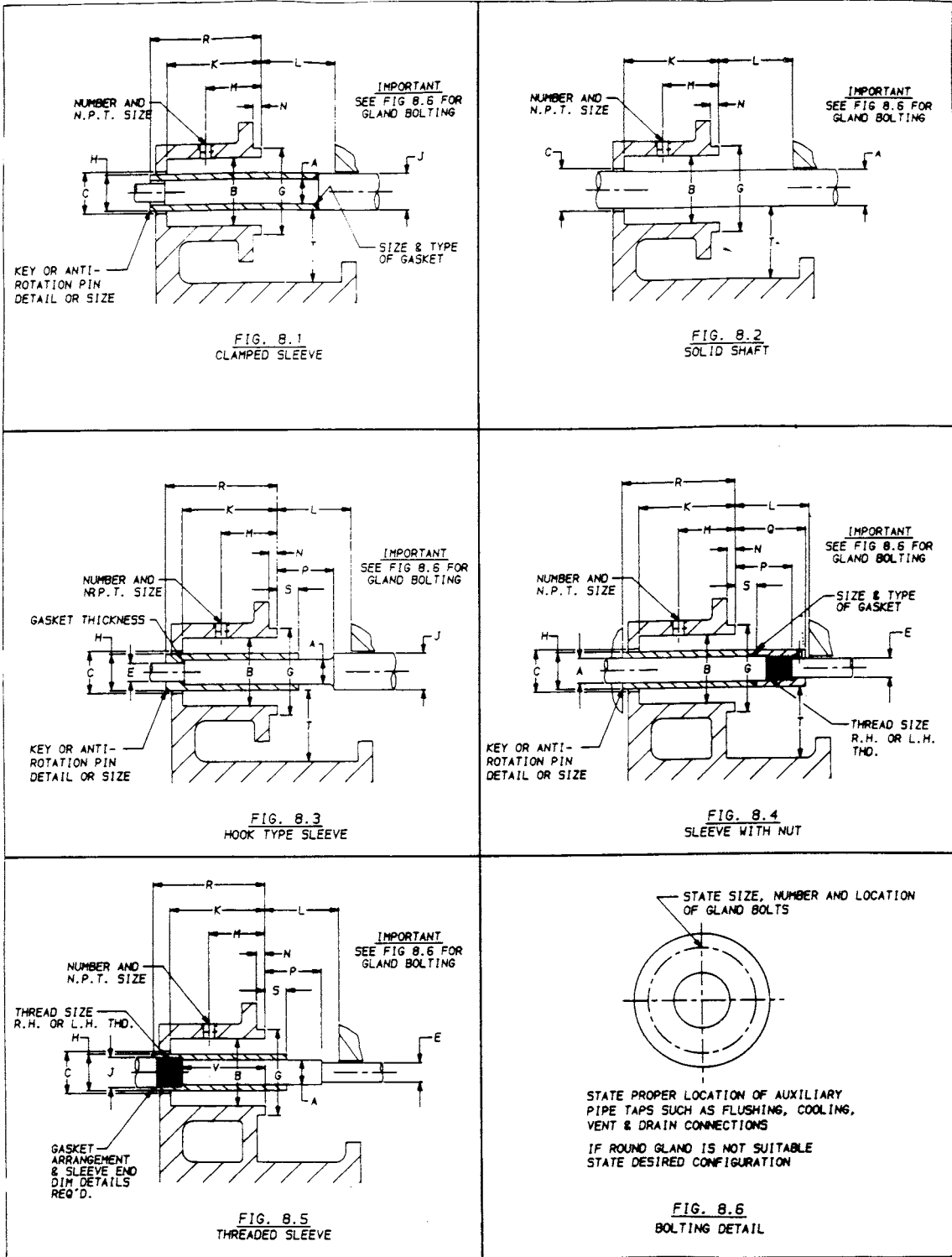

FIG. 8 Stuffing Box Arrangement

Refer to Fig. 8

A. _____	K. _____
B. _____	L. _____
C. _____	M. _____
D. _____	N. _____
E. _____	P. _____
F. _____	R. _____
G. _____	S. _____
H. _____	T. _____
J. _____	U. _____
N.P.T. _____	
Bolt Holes or Stud Loc. _____	
Thread Size _____	
Auxiliary Pipe Tap Loc. _____	
Comments _____	

FIG. 9 Stuffing Box Dimensions

TABLE 1 Metal Component Compatibility

NOTE 1—For fluids or materials not covered here, seal selection to be mutually agreed upon by seal manufacturer, pump supplier, and end user.
 NOTE 2— X = Suitable for use as seal components.

Fluid	Materials ^A						
	Brass	316 Stainless Steel	Ni-Cu	Alloy 20	Highly Alloyed Stainless Steel	Ni-Mo	Ni-Cr-Mo-Cb Ni-Cr-Fe
<i>Fresh Water</i>							
Demineralized water		X		X	X	X	X
Boiler feed		X		X	X	X	X
Potable	X	X	X	X	X	X	X
<i>Salt Water</i>							
Seawater			X	X	X	X	X
Distiller brine			X		X	X	X
<i>Fuel Oil</i>							
Navy distillate		X	X	X	X	X	X
JP-5		X	X	X	X	X	X
Diesel		X	X	X	X	X	X
Kerosene		X	X	X	X	X	X
Crude oil		X	X	X	X	X	X
Lube oil		X	X	X	X	X	X
Sewage			X	X	X	X	X

^A See Section 6 for material specifications.

6.5.2.2 Chloroprene—Practice **D 1418**, Class Designation CR.

6.5.2.3 Fluorocarbon—Practice **D 1418**, Class Designation FKM.

6.5.2.4 Ethylene Propylene (EP)—Practice **D 1418**, Class Designation EPM/EPDM.

6.5.2.5 Perfluoroelastomer—Practice **D 1418**, Class Designation FFKM.

6.5.2.6 Polytetrafluorethylene (PTFE)—Specification **D 3294**.

6.5.2.7 Corrugated graphite ribbon packing.

6.5.3 Ethylene propylene (EP) rubber shall not be lubricated with any petroleum base substances. Check Section **11** and **Appendix X1** or manufacturer’s recommendations before using any lubricant.

7. Performance Requirements

7.1 Seal life shall be defined in terms of the time period in which the mechanical seal functions properly under its specified service.

TABLE 2 Seal Face Materials

NOTE 1—Faces for chemically active materials and special applications shall be agreed upon by seal manufacturer and end user.

Seal Face Compatibility Chart		
Primary Ring	Mating Ring	PV Limit, ^A lb/in. ² × ft/min (MPa·m/s)
Carbon	Tungsten carbide	500 000 (17.75)
Carbon	Silicon carbide	500 000 (17.75)
Carbon	Ceramic ^B	100 000 (3.55)
Siliconized carbon	Tungsten carbide	350 000 (12.43)
Siliconized carbon	Silicon carbide	350 000 (12.43)
Silicon carbide	Tungsten carbide	300 000 (10.65)
Silicon carbide	Silicon carbide	350 000 (12.43)
Tungsten carbide	Tungsten carbide	120 000 ^C (4.26)

^A Values of PV apply to aqueous solutions at 120°F (49°C). For lubricating liquids, such as oil, 60 % higher can be used. Given limits are to be used as a general guide in material selection. Values used consider a pressure drop across the seal faces as 0.5.

^B Limited to chemical service requirements only.

^C PV limit of 185 000 (6.57) can be used with two different grades of tungsten carbide, that is, cobalt versus nickel binders.

7.1.1 The minimum operational life of a mechanical seal shall be 16 000 statistical hours provided that the equipment is maintained and operated in accordance with the requirements of Section 8.

7.1.2 During any portion of the service life, the dynamic leakage shall not exceed five drops per minute for Class 0 seals. After initial installation, hydrostatic leakage shall be zero for a 5-min period, when the equipment is subjected to system pressure.

7.1.3 All split mechanical seals, Classes 1 through 4, may experience higher leakage rates than Class 0, solid mechanical seals. A leakage rate of five drops per minute shall be acceptable after completion of the manufacturer's recommended break-in period.

7.1.4 In special applications of extreme environmental parameters, such as high temperature with limited cooling, high pressure/velocity, extreme abrasion, unusual equipment vibration, shaft end-play, or run-out, the pump and seal manufacturers shall agree upon the best achievable minimum operating life requirements and leakage performance.

7.1.5 Double or special seal arrangements may be required in applications in which zero product leakage to the environment is required such as hazardous fluids, fuel oil, acids, chemicals, and sewage. Consult the seal manufacturer for recommendations.

8. Design Requirements Design Requirements

8.1 Installation Arrangements:

8.1.1 Type A mechanical seals shall be provided unless otherwise specified.

8.1.2 Tandem or double mechanical seals may be installed in special applications in which it is determined that a buffer fluid system is required for lubrication, containment, or safety.

8.2 Finish and tolerance requirements for primary seal ring and mating ring surface flatness of Class 0 mechanical seals shall be three light bands or better as measured under a monochromatic, helium light source.

8.3 Requirements for Installation of Classes 1 Through 4 Split Mechanical Seals:

8.3.1 Classes 1 through 4, split mechanical seals, may be furnished for shaft/sleeve diameters of 1½ in. (38.1 mm) and above.

8.3.2 For split mechanical seal installations, a minimum of 3 in. (76.2 mm) of axial space, measured from the stuffing box face to the first obstruction, shall be provided for Classes 2 and 4 seals. Additional space, at least equal to the gland thickness, may be required for Classes 1 and 3 seals.

8.3.3 Classes 1 through 4, split mechanical seals, shall be designed to operate under a minimum reverse differential pressure condition of 15-in. Hg (50.8 kPa).

8.4 The requirement for a balanced or unbalanced seal will vary dependent upon the combination of various design and performance factors. Balanced seals shall normally be supplied for pressures greater than 150 psi (1.03 MPa) unless the seal manufacturer provides alternative recommendations for specific applications. Selection of a balanced or unbalanced seal design must satisfy the performance requirements of Section 7.

8.5 The mechanical seal shall be designed to operate satisfactorily under the following:

8.5.1 Shaft sleeve surface finish for pusher-type seals shall be 32 rms (0.80 µm) maximum. Shaft sleeve surface finish for nonpusher seals shall be 64 rms (1.60 µm) maximum.

8.5.2 Shaft radial run-out 0.010 in. (0.25 mm) TIR maximum.

8.5.3 Shaft end-play maximum ±0.015 in. (0.38 mm).

8.5.4 Concentricity of stuffing box bore to shaft axis 0.005 in. (0.13 mm) TIR maximum. Gland plate design must accommodate eccentricity stated herein.

8.5.5 Perpendicularity of stuffing box face to shaft axis 0.003 in. (0.08 mm) TIR maximum.

8.6 *Environmental Controls*—Environmental control considerations, such as flushing, cooling, heating, and quenching shall be specified by the seal manufacturer.

9. Quality Assurance Provisions

9.1 *Quality Systems*—Mechanical seals shall be supplied in accordance with **ISO 9001**.

9.2 *Responsibility for Inspection*—Unless otherwise specified, the manufacturer is responsible for the performance of all inspection requirements. The manufacturer may use his own or any other facilities suitable for inspection. The purchaser (buyer) reserves the right to perform any of the inspections set forth in the specification where such inspections are deemed necessary to assure supplies and services conform to prescribed requirements.

9.3 *Material Inspection*—The manufacturer shall be responsible for ensuring that materials used are manufactured, examined, and tested in accordance with the specifications and standards as applicable.

9.4 *Classification of Inspections*—The inspection requirements specified herein shall be classified as follows:

9.4.1 *Quality Conformance Inspection*.

9.4.2 *Inspection of Packaging*.

9.5 *Quality Conformance Inspection*—All seal components shall be inspected in accordance with **ASQC Z1.4** listing critical, major, and minor characteristics and type of inspection equipment used to determine said characteristics.

TABLE 3 Elastomer Compatibility

NOTE 1—X = Suitable for fluids within temperature range indicated.

Fluid Temp. Limits: Min Max	Nitrile-N –50°F (–46°C) +250°F (121°C)	Fluorocarbon ^A –25°F (–32°C) +400°F (204°C)	PTFE ^B –150°F (–101°C) +500°F (260°C)	Corrugated Graphite Ribbon –400°F (–46°C) +750°F (400°C)	EP –50°F (–46°C) +300°F (149°C)	Chloroprene –50°F (–46°C) +200°F (93°C)
<i>Fresh Water</i>						
Demineralized water	X	X	X	X	X	X
Boiler feedwater		X	X	X	X	
Potable water	X	X	X	X	X	X
<i>Salt Water</i>						
Seawater	X	X	X	X	X	X
Distiller brine		X	X	X	X	
<i>Fuel and Lubricants</i>						
Navy distillate	X	X	X	X		X
JP-5	X	X	X	X		X
Bunker C		X	X	X		X
Diesel oil	X	X	X	X		X
Kerosene	X	X	X	X		X
Lube oil (mineral base)		X	X	X		
Sewage	X	X	X	X	X	X

^A Fluorocarbon shall be limited to 275°F (135°C) in water.

^B Care should be used in selecting PTFE. Its use is only dictated when other elastomers are not suitable and PTFE is acceptable. PTFE is not acceptable for nuclear service, or in a radiation area. Glass-filled PTFE has a temperature range of –350°F (–212°C) to +500°F (260°C).

9.5.1 *Acceptable Quality Level for Characteristics*—The acceptable quality levels for characteristics, as per **ASQC Z1.4**, shall be as follows:

9.5.1.1 Critical—1.5 AQL.

9.5.1.2 Major—2.5 AQL.

9.5.1.3 Minor—4.0 AQL.

9.5.2 *Tests*—All tests shall be performed in accordance with ASTM, ASME, or manufacturer’s standards as specified.

9.5.3 *Test Data*—All test data shall remain on file at the manufacturer’s facility for review by buyer upon request. It shall be retained in the manufacturer’s files for at least three years.

9.6 *Inspection of Packaging:*

9.6.1 *Unit of Product*—For the purpose of inspection, a completed package prepared for shipment shall be considered as a unit of product.

9.6.2 *Sampling*—Sampling for examination shall be in accordance with **ASQC Z1.4**. The AQL shall be 4.0 % defective.

9.6.3 *Examination*—Samples selected in accordance with **9.5.2** shall be examined for the following defects:

9.6.3.1 Materials, methods, container,

9.6.3.2 Strapping,

9.6.3.3 Consolidated seals not of like description, and

9.6.3.4 Marking illegible, incorrect, incomplete, or missing.

9.7 *Warranty:*

9.7.1 *Responsibility for Warranty*—Unless otherwise specified, the manufacturer is responsible for the following:

9.7.1.1 All materials used to produce a unit,

9.7.1.2 Workmanship, and

9.7.1.3 Manufacturer will warrant his product to be free from defect of workmanship.

9.8 *Certification*—When specified in the purchase order or contract, the purchaser (buyer) shall be furnished certification that samples representing each lot have been either tested or

inspected as directed in this specification and the requirements have been met. When specified in the purchase order or contract, a report of the test results shall be furnished.

10. Packing and Preparation for Delivery

10.1 *Unit of Product*—For the purpose of inspection, a completed package prepared for shipment shall be considered as a unit of product.

10.2 *Packaging of Product for Delivery*—Product should be packaged for shipment in accordance with standard industry practice.

10.3 *Instructions*—Instructions and manufacturer’s special provisions for handling shall be included in complete package.

10.3.1 Each of Classes 1 through 4, split mechanical seals, shall be supplied with detailed assembly and installation instructions.

10.3.2 All special or nonstandard tools and fixtures required to assemble and install the seal in the pump shall be identified and supplied with each seal package.

10.4 Any special packaging requirements for shipment or storage shall be identified in the ordering data. See Section 5.

10.5 *Marking and Coding*—When specified, a mechanical seal marking and coding system shall be used in accordance with **Appendix X2**.

11. Installation of the Seal Assembly

11.1 Seal suppliers shall provide instructions for each mechanical seal installation to include the applicable information required herein as a minimum.

11.2 Because of the variety of seal types and designs, **Appendix X1** is provided for general guidance.

11.3 For specific detailed instructions, consult the seal supplier’s installation procedures. For reference to component identification terms, see Section 3 and **Annex A1**.

SUPPLEMENTARY REQUIREMENTS

The following supplementary requirements established by the U.S. Navy, Commander Naval Sea Systems Command (NAVSEA), shall apply when specified in the contract or purchase order. When there is a conflict between the specifications and this Supplement S1, the requirements of Supplement S1 shall take precedence.

S1. Scope

- S1.1 This supplementary requirement applies to mechanical end face seals for use in U.S. Navy shipboard pumps.
- S1.2 Magnetic seals shall not be used.

S2. Referenced Documents

- S2.1 *ASTM Standards:*
 - D 1141 Specification for Substitute Ocean Water
 - D 3951 Practice for Commercial Packaging
- S2.2 *Military Standards:*⁵
 - MIL-S-901 Shock Tests, H.I. (High Impact); Shipboard Machinery, Equipment & Systems, Requirements for
 - MIL-P-16789 Packaging of Pumps, Including Prime Movers and Associated Repair Parts
 - MIL-R-83248 Rubber Fluorocarbon Elastomer, High Temperature, Fluid, and Compression Set Resistant
 - MS16142 Standard Dimensions for Gasket Seal Straight Thread Tube Fitting
 - MIL-STD-167-1 Environmental Vibration Testing

S3. Terminology:

- S3.1 See [Annex A1](#).

S4. Classification and Seal Arrangements:

- S4.1 See Section 4.

S5. Design Requirements

S5.1 All mechanical seals shall meet the dimensional requirements from the applicable [Tables S1-S4](#). Guidelines for seal/pump for S5 and S6 seals for cartridge and split mechanical seals are provided in [Tables S5 and S6](#). Mechanical seals as shown in [Table S1](#) Standard Long Mechanical Seals and [Table S2](#) Standard Short Mechanical Seals, shall be of the single spring elastomeric bellows type. Slot details for antirotation pins applicable to [Table S1](#) and [Table S2](#) are shown in [Fig. S2](#).

S5.2 Pusher type seals may be used for hydraulic oils, fuels, and lubricants.

S5.3 Mechanical seals to [Tables S1-S4](#) shall be axially positioned or located on the shaft by positive means such as a stub, step, or shoulder on the shaft or a sleeve that is positively located on the shaft.

S5.4 Mechanical seals to [Tables S1-S4](#) shall not be axially positioned by the use of set screws.

S5.5 Any special tools or spacers required to install and remove a mechanical seal shall be included with the seal.

S5.6 Mechanical seals supplied in accordance with [Table S5](#) shall meet the following requirements:

S5.6.1 [Table S5](#) mechanical seals may use setscrews to position the seal.

S5.6.2 A throttle bushing or secondary containment seal shall be used to limit leakage in event of seal failure. The diametrical clearance of the throttle bushing bore shall not be more than 0.025 in. for sleeve diameters up to 2.0 in. For larger diameters, the maximum diametrical clearance shall be 0.025 in. plus 0.005 in. for each additional 1.0 in. of diameter or fraction thereof. Mechanical seals used for lube oil and fuel services may use backup packing instead of throttle bushings.

S5.6.3 Non-sparking metallic assembly clips shall be used.

S5.6.4 Throttle bushing drain and seal flushing connections shall be provided with straight “O” ring fittings to MS 16142, minimum size 3/8-in.

S5.7 Mechanical seals supplied in accordance with [Table S6](#) shall meet the following requirements:

S5.7.1 No provision for back-up packing is required for split mechanical seals unless requested by the customer.

S5.7.2 Split mechanical seals shall not be used for fuel or lube oil service pumps.

S5.7.3 Mechanical seals supplied in accordance with [Table S6](#) may leak at the seal faces during hydrostatic testing of the pump.

S5.8 Type E mechanical seals shall be the non-contacting design where the mating faces are designed to intentionally create aerodynamic or hydrodynamic separating forces to sustain a specific separation gap.

S5.8.1 Type E seals shall be used only on fuel/oil services with a shaft speed greater than 300 ft per min (fpm) measured at the shaft diameter.

S5.8.2 Nodular or graphitic ductile nickel cast iron mating rings allowed per [Table S7](#) are not permitted in Type E seals.

S5.8.3 A self-contained gas seal support system (GSSS) shall be provided. The GSSS shall include check valve, gas regulator, pressure gage, and flowmeter. The GSSS components shall be enclosed in a box to protect from the elements. Flow and pressure indicators shall be visible from the outside of the box. GSSS shall be used to support the Type E seal during Section S7 testing. The GSSS shall undergo shock testing in accordance with MIL-S-901 and environmental vibration testing in accordance with MIL-STD-167-1.

S5.9 Unless otherwise specified, the seal manufacturer shall prepare drawings in accordance with ANSI Standards Y14.1, Y14.2, Y14.3, Y14.5, Y14.6, and Y14.26.3.

S5.9.1 Drawings shall be furnished under each contract or order unless the complete equipment covered by the drawings are identical in all respects to those previously submitted.

S5.9.2 Information intended for manufacturer’s use only shall be so designated.

S5.10 Drawings for each mechanical seal shall include a sectional assembly drawing and component detail drawings.

TABLE S1 Standard Long Mechanical Seal

NOTE 1—Standard (long) mechanical seal dimensions for Navy shipboard pump applications (low pressure, 150 psi (1.03 MPa) max, for new or replacement applications).

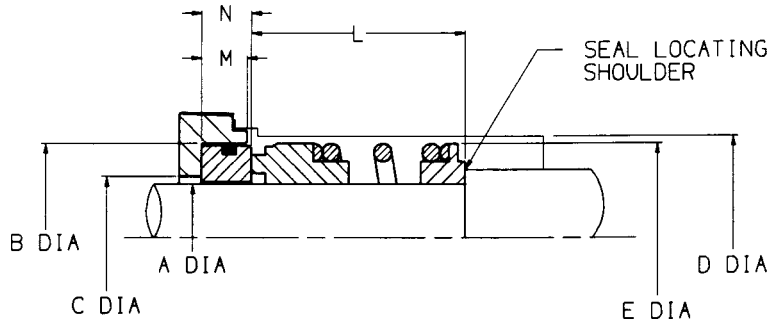

A ±	(A') ±	B ±	(B') ±	C	(C')	D	(D')	E	(E')	L ±	(L') ±	(M) ±	(M') ±	(N) ±	(N') ±
0.002	0.05	0.002	-0.05	REF	REF	min	min	max	max	0.020	-0.5	0.005	0.12	0.15	0.38
0.375	9.52	0.875	22.23	0.438	11.13	1.062	26.98	0.937	23.80	1.188	30.2	0.250	6.35	0.312	7.92
0.500	12.70	1.000	25.40	0.563	14.30	1.187	30.15	1.062	26.97	1.188	30.2	0.250	6.35	0.312	7.92
0.625	15.87	1.250	31.75	0.688	17.48	1.343	34.12	1.218	30.93	1.312	33.3	0.344	8.74	0.406	10.31
0.750	19.05	1.375	34.93	0.813	20.65	1.468	37.29	1.343	34.11	1.312	33.3	0.344	8.74	0.406	10.31
0.875	22.22	1.500	38.10	0.938	23.83	1.656	42.07	1.531	38.88	1.375	34.9	0.344	8.74	0.406	10.31
1.000	25.40	1.625	41.28	1.063	27.00	1.750	44.45	1.625	41.27	1.562	39.7	0.375	9.53	0.438	11.13
1.125	28.57	1.750	44.45	1.188	30.18	1.870	47.50	1.745	44.32	1.625	41.3	0.375	9.53	0.438	11.13
1.250	31.75	1.875	47.63	1.313	33.35	2.000	50.80	1.875	47.62	1.625	41.3	0.375	9.53	0.438	11.13
1.375	34.92	2.000	50.80	1.438	36.53	2.125	53.98	2.000	50.80	1.687	42.9	0.375	9.53	0.438	11.13
1.500	38.10	2.125	53.98	1.563	39.70	2.250	57.15	2.125	53.97	1.687	42.9	0.375	9.53	0.438	11.13
1.625	41.27	2.375	60.33	1.688	42.88	2.500	63.50	2.375	60.32	2.000	50.8	0.438	11.13	0.500	12.70
1.750	44.45	2.500	63.50	1.813	46.05	2.625	66.68	2.500	63.50	2.000	50.8	0.438	11.13	0.500	12.70
1.875	47.62	2.625	66.68	1.938	49.23	2.750	69.85	2.625	66.67	2.125	54.0	0.438	11.13	0.500	12.70
2.000	50.80	2.750	69.85	2.063	52.40	2.937	74.60	2.812	71.42	2.125	54.0	0.438	11.13	0.500	12.70
2.125	53.97	3.000	76.20	2.188	55.58	3.125	79.38	3.000	76.20	2.375	60.3	0.500	12.70	0.562	14.27
2.250	57.15	3.125	79.38	2.313	58.75	3.250	82.55	3.125	79.37	2.375	60.3	0.500	12.70	0.562	14.27
2.375	60.32	3.250	82.55	2.438	61.93	3.375	85.73	3.250	82.55	2.500	63.5	0.500	12.70	0.562	14.27
2.500	63.50	3.375	85.73	2.563	65.10	3.500	88.90	3.375	85.72	2.500	63.5	0.500	12.70	0.562	14.27
2.625	66.67	3.375	85.73	2.688	68.28	3.750	95.25	3.625	92.07	2.750	69.8	0.562	14.30	0.625	15.87
2.750	69.85	3.500	88.90	2.813	71.45	3.875	98.43	3.750	95.25	2.750	69.8	0.562	14.30	0.625	15.87
2.875	73.02	3.750	95.25	2.938	74.63	4.000	101.60	3.875	98.42	2.875	73.0	0.562	14.30	0.625	15.87
3.000	76.20	3.875	98.43	3.125	79.38	4.187	106.35	4.062	103.17	2.875	73.0	0.562	14.30	0.625	15.87
3.125	79.37	4.000	101.60	3.250	82.55	4.437	112.70	4.250	107.95	3.125	79.4	0.656	16.66	0.781	19.84
3.250	82.55	4.125	104.78	3.375	85.73	4.562	115.88	4.375	111.12	3.125	79.4	0.656	16.66	0.781	19.84
3.375	85.72	4.250	107.95	3.500	88.90	4.687	119.05	4.500	114.30	3.125	79.4	0.656	16.66	0.781	19.84
3.500	88.90	4.375	111.13	3.625	92.08	4.812	122.23	4.625	117.47	3.125	79.4	0.656	16.66	0.781	19.84
3.625	92.07	4.500	114.30	3.750	95.25	4.937	125.40	4.750	120.65	3.250	82.6	0.656	16.66	0.781	19.84
3.750	95.25	4.625	117.48	3.875	98.43	5.062	128.58	4.875	123.82	3.250	82.6	0.656	16.66	0.781	19.84
3.875	98.42	4.750	120.65	4.000	101.60	5.187	131.75	5.000	127.00	3.375	85.7	0.656	16.66	0.781	19.84
4.000	101.60	4.875	123.83	4.125	104.78	5.312	134.93	5.125	130.17	3.375	85.7	0.656	16.66	0.781	19.84

Notes:

A to N = English units. A' to N' = SI (metric) units.

- I) For mating ring antirotation slot detail see Fig. S2
- II) B—Gland counterbore
 C—Min shaft clearance bore recommended tolerance + 0.030 (0.076)/-0.000
 D—Min stuffing box bore
 E—Max seal O.D. (within stuffing box)

TABLE S2 Standard Short Mechanical Seal

NOTE 1—Standard (short length), mechanical seal dimensions for Navy shipboard pump applications (low pressure, 150 psi (1.03 MPa) max, for new or replacement applications).

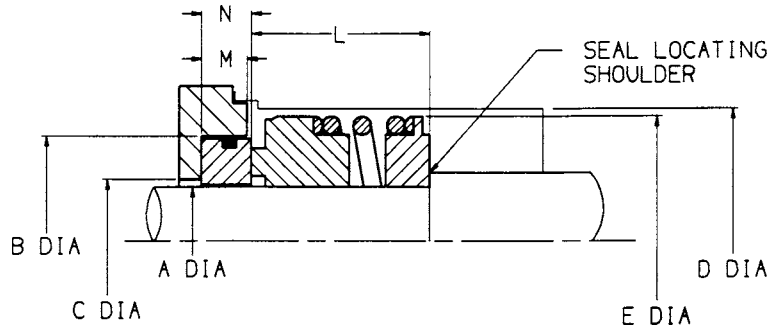

A ±	(A') ±	B ±	(B') ±	C	(C')	D	(D')	E	(E')	L ±	(L') ±	(M) ±	(M') ±	(N) ±	(N') ±
0.002	0.05	0.002	-0.05	REF	REF	min	min	max	max	0.020	-0.5	0.005	0.12	0.15	0.38
0.375	9.52	0.875	22.23	0.438	11.13	1.218	30.94	1.031	26.18	0.812	20.7	0.250	6.35	0.312	7.92
0.500	12.70	1.000	25.40	0.563	14.30	1.375	34.93	1.187	30.15	0.812	20.7	0.250	6.35	0.312	7.92
0.625	15.87	1.250	31.75	0.688	17.48	1.562	39.68	1.375	34.92	0.875	22.7	0.344	8.74	0.406	10.31
0.750	19.05	1.375	34.93	0.813	20.65	1.687	42.85	1.500	38.10	0.875	22.7	0.344	8.74	0.406	10.31
0.875	22.22	1.500	38.10	0.938	23.83	1.812	46.03	1.625	41.27	0.937	23.8	0.344	8.74	0.406	10.31
1.000	25.40	1.625	41.28	1.063	27.00	2.000	50.80	1.812	46.02	1.000	25.4	0.375	9.53	0.438	11.13
1.125	28.57	1.750	44.45	1.188	30.18	2.125	53.98	1.937	49.20	1.062	27.0	0.375	9.53	0.438	11.13
1.250	31.75	1.875	47.63	1.313	33.35	2.250	57.15	2.062	52.37	1.062	27.0	0.375	9.53	0.438	11.13
1.375	34.92	2.000	50.80	1.438	36.53	2.437	61.90	2.250	57.15	1.125	28.6	0.375	9.53	0.438	11.13
1.500	38.10	2.125	53.98	1.563	39.70	2.562	65.08	2.375	60.32	1.125	28.6	0.375	9.53	0.438	11.13
1.625	41.27	2.375	60.33	1.688	42.88	2.937	74.60	2.718	69.03	1.375	34.9	0.438	11.13	0.500	12.70
1.750	44.45	2.500	63.50	1.813	46.05	3.062	77.78	2.750	69.85	1.375	34.9	0.438	11.13	0.500	12.70
1.875	47.62	2.625	66.68	1.938	49.23	3.187	80.95	2.875	73.02	1.500	38.1	0.438	11.13	0.500	12.70
2.000	50.80	2.750	69.85	2.063	52.40	3.312	84.13	3.000	76.20	1.500	38.1	0.438	11.13	0.500	12.70
2.125	53.97	3.000	76.20	2.188	55.58	3.625	92.08	3.250	82.55	1.687	42.9	0.500	12.70	0.562	14.27
2.250	57.15	3.125	79.38	2.313	58.75	3.750	95.25	3.375	85.72	1.687	42.9	0.500	12.70	0.562	14.27
2.375	60.32	3.250	82.55	2.438	61.93	3.875	98.43	3.500	88.90	1.812	46.0	0.500	12.70	0.562	14.27
2.500	63.50	3.375	85.73	2.563	65.10	4.000	101.60	3.625	92.07	1.812	46.0	0.500	12.70	0.562	14.27
2.625	66.67	3.375	85.73	2.688	68.28	4.312	109.53	3.875	98.42	1.937	49.2	0.562	14.30	0.625	15.87
2.750	69.85	3.500	88.90	2.813	71.45	4.437	112.70	4.000	101.60	1.937	49.2	0.562	14.30	0.625	15.87
2.875	73.02	3.750	95.25	2.938	74.63	4.562	115.88	4.125	104.77	2.062	52.4	0.562	14.30	0.625	15.87
3.000	76.20	3.875	98.43	3.125	79.38	4.687	119.05	4.250	107.95	2.062	52.4	0.562	14.30	0.625	15.87
3.125	79.37	4.000	101.60	3.250	82.55	5.000	127.00	4.562	115.87	2.187	55.6	0.656	16.66	0.781	19.84
3.250	82.55	4.125	104.78	3.375	85.73	5.125	130.18	4.687	119.05	2.187	55.6	0.656	16.66	0.781	19.84
3.375	85.72	4.250	107.95	3.500	88.90	5.250	133.35	4.812	122.22	2.187	55.6	0.656	16.66	0.781	19.84
3.500	88.90	4.375	111.13	3.625	92.08	5.500	139.70	4.937	125.40	2.187	55.6	0.656	16.66	0.781	19.84
3.625	92.07	4.500	114.30	3.750	95.25	5.687	144.45	5.125	130.17	2.312	58.8	0.656	16.66	0.781	19.84
3.750	95.25	4.625	117.48	3.875	98.43	5.812	147.63	5.250	133.35	2.312	58.8	0.656	16.66	0.781	19.84
3.875	98.42	4.750	120.65	4.000	101.60	6.000	152.40	5.437	138.10	2.437	61.9	0.656	16.66	0.781	19.84
4.000	101.60	4.875	123.83	4.125	104.78	6.125	155.58	5.562	141.27	2.437	61.9	0.656	16.66	0.781	19.84

Notes:

A to N = English units. A' to N' = SI (metric) units.

- i) For mating ring antirotation slot detail see Fig. S2
- ii) B—Gland counterbore
 C—Min shaft clearance bore recommended tolerance + 0.030 (0.076)/-0.000
 D—Min stuffing box bore
 E—Max seal O.D. (within stuffing box)

TABLE S3 Special Cartridge Seals Grade 2

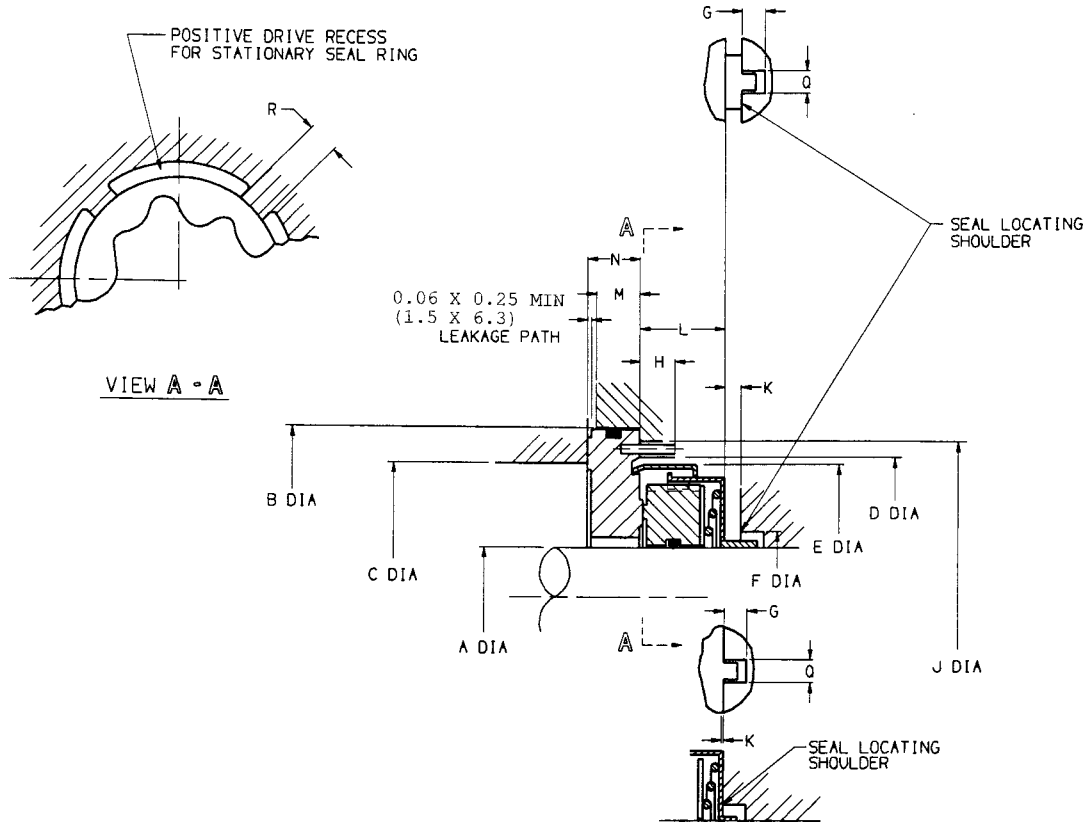

A ±	(A') ±	B ±	(B') ±	C	(C')	D	(D')	E	(E')	E	(F')	G	(G')	H	(H')
0.002	0.05	0.002	0.05	Ref	Ref	min	min	max	max	min	min	min	min	max	max
1.186	30.12	3.066	77.88	2.726	69.24	2.44	61.98	2.348	59.64	1.29	32.77	0.19	4.83	0.50	12.70
1.377	34.98	3.066	77.88	2.726	69.24	2.44	61.98	2.420	61.47	1.51	38.35	0.31	7.87	0.50	12.70
1.436	36.47	3.877	98.48	3.416	86.77	2.94	74.68	2.763	70.18	1.54	39.12	0.19	4.83	0.62	15.75
1.771	44.98	3.877	98.48	3.416	86.77	2.94	74.68	2.861	72.67	2.00	50.80	0.12	3.05	0.62	15.75
J	(J')	K	(K')	L ±	(L') ±	M ±	(M') ±	N ±	(N') ±	Q	(Q')	R	(R')		
min	min	min	min	0.20	0.5	0.005	0.13	0.015	0.38	min	min	max	max		
2.82	71.63	00	00	0.741	18.82	0.340	8.64	0.408	10.36	0.25	6.35	0.38	9.65		
2.82	71.63	0.18	4.57	0.794	20.17	0.340	8.64	0.408	10.36	0.31	7.87	0.38	9.65		
3.56	90.42	00	00	0.820	20.83	0.380	9.65	0.408	10.36	0.31	7.87	0.50	12.70		
3.56	90.42	00	00	0.877	22.28	0.380	9.65	0.408	10.36	0.31	7.87	0.50	12.70		

Notes:

A to R = English units. A' to R' = SI (metric) units.

B—Gland counterbore

C—Seal support shoulder tolerance + 0.030 (0.76)/-0.000

D—Minimum stuffing box bore

E—Maximum seal O.D. (within stuffing box)

F—Positive drive recess for seal assembly drive lug. 2 each 180° apart

G—Positive drive recess for seal assembly drive lug. 2 each 180° apart

H—Maximum pin length shown, max pin diameter 0.125

J—Positive drive recess for stationary seal ring

K—Clearance required between seal and seal locating shoulder

R—Four lugs equally spaced at 90°

TABLE S4 Special Cartridge Seals Grade 1

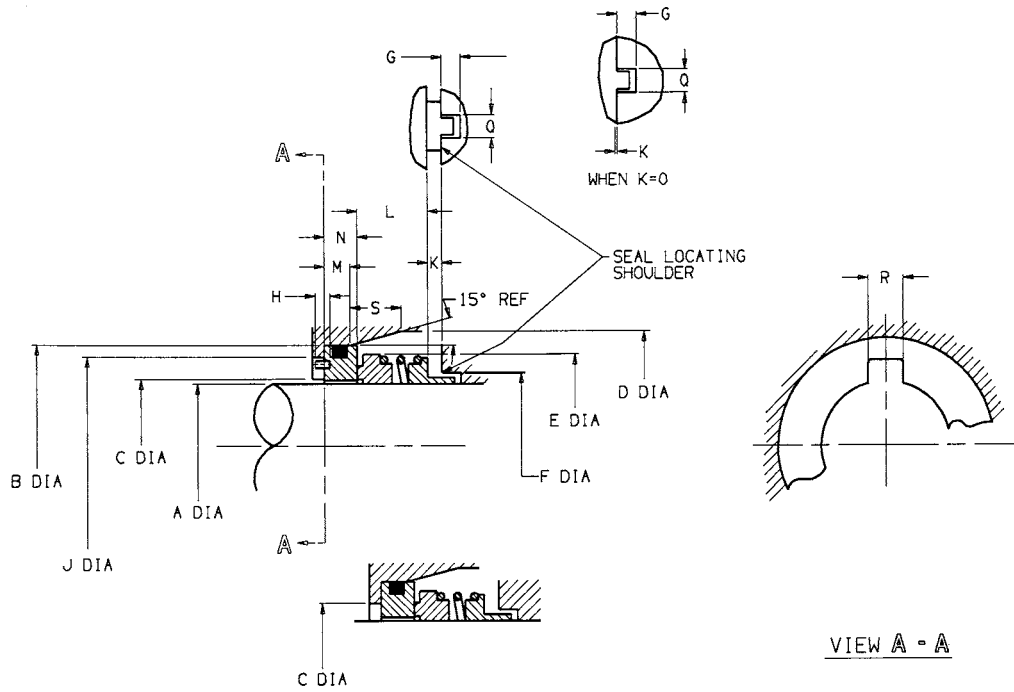

VIEW FOR 0.811 (20.60) SHAFT SIZE ONLY

A ±	(A') ±	B ±	(B') ±	C	(C')	D	(D')	E	(E')	E	(F')	G	(G')	H	(H')
0.002	0.05	0.002	0.05	Ref	(C') Ref	D min	(D') min	E max	(E') max	E min	(F') min	G min	(G') min	H max	(H') max
0.811	20.60	1.851	47.02	1.605	40.77	1.67	42.42	1.583	40.21	0.94	23.88	0.12	3.02	NA	NA
1.000	25.40	1.877	47.68	1.100	27.94	2.09	53.09	2.011	51.08	1.10	27.94	0.09	2.29	0.13	3.30
1.876	47.65	2.752	69.90	2.100	53.34	3.36	85.34	3.315	84.20	2.00	50.80	0.21	5.33	0.18	4.57
2.162	54.91	3.127	79.43	2.218	56.34	3.60	91.44	3.252	82.60	2.38	60.45	0.31	7.87	0.18	4.57
2.750	69.85	4.002	10.17	2.875	73.03	4.47	113.54	4.310	109.47	3.05	77.47	0.44	11.18	0.10	2.54

J	(J')	K	(K')	L ±	(L') ±	M ±	(M') ±	N ±	(N') ±	Q	(Q')	R	(R')	S	(S')
min	min	min	min	020	0.5	0.005	0.13	0.015	0.38	min	min	max	max	max	min
NA	NA	0.190	4.83	0.679	17.25	0.280	7.11	0.362	9.19	0.19	4.83	NA	NA	NA	NA
1.44	36.58	000	000	0.590	14.99	0.250	6.35	0.317	8.05	0.25	6.35	0.38	9.65	0.190	1.83
2.34	59.44	0.250	6.35	0.868	22.05	0.250	6.35	0.437	11.10	0.31	7.87	0.38	9.65	0.128	3.25
2.70	68.58	0.595	15.11	0.770	19.56	0.280	7.11	0.375	9.53	0.31	7.87	0.38	9.65	0.254	6.45
3.44	87.38	0.250	6.35	1.002	25.45	0.280	7.11	0.500	12.70	0.44	11.18	0.38	9.65	0.230	5.84

Notes:

A to S = English units. A' to S' = SI (metric) units.

B—Gland counterbore

C—Seal support shoulder tolerance + 0.030 (0.76)/-0.000

D—Minimum stuffing box bore

E—Maximum seal O.D. (within stuffing box)

F—Positive drive recess for seal assembly drive lug. 2 each 180° apart

G—Positive drive recess for seal assembly drive lug. 2 each 180° apart

H—Maximum pin length shown, max pin diameter 0.125

J—Positive drive recess for stationary seal ring

K—Clearance required between seal and seal locating shoulder 2 each 180° apart

R—One recess only

N/A—Not applicable

TABLE S5 Cartridge Seal

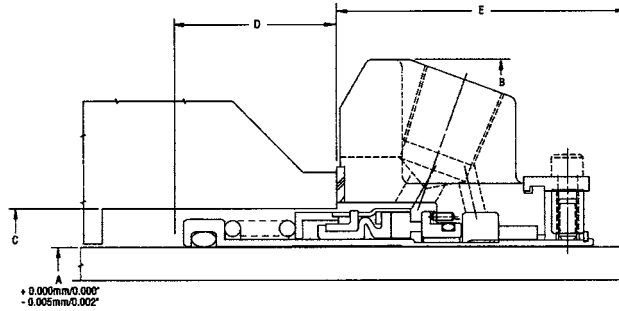
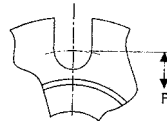
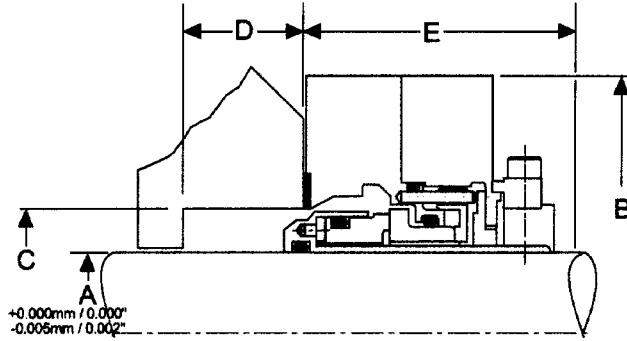

Maximum Dimensions for Seal Installation

A Shaft Size	B Gland OD	C Box Bore min	C Box Bore max	D Box Depth min	E Nearest Obstruction	F Bolt Circle min Bolt Size 5/8 in.	F Bolt Circle min Bolt Size 1/2 in.	F Bolt Circle min Bolt Size 5/8 in.	F Bolt Circle min Bolt Size 3/4 in.
1.000	4.11	1.63	1.88	0.91	2.11	2.88	N/A	N/A	N/A
1.125	4.13	1.75	2.01	0.66	2.13	2.88	N/A	N/A	N/A
1.250	4.25	1.88	2.27	0.78	2.13	3.14	3.25	N/A	N/A
1.375	4.38	2.00	2.33	0.69	2.13	3.26	3.34	N/A	N/A
1.500	4.88	2.21	2.44	0.96	2.19	3.48	3.60	N/A	N/A
1.625	5.00	2.34	2.69	1.02	2.19	N/A	3.77	N/A	N/A
1.750	5.49	2.50	2.81	1.04	2.19	N/A	3.88	N/A	N/A
1.875	5.49	2.63	2.91	1.04	2.19	N/A	3.91	N/A	N/A
2.000	5.50	2.75	3.01	1.27	2.38	N/A	4.16	N/A	N/A
2.125	5.86	2.88	3.44	1.27	2.38	N/A	4.41	4.50	N/A
2.250	6.50	3.00	3.48	1.39	2.38	N/A	4.53	4.62	N/A
2.375	6.50	3.13	3.59	1.13	2.53	N/A	4.60	4.72	N/A
2.500	6.75	3.37	3.81	1.39	2.63	N/A	4.88	5.00	N/A
2.625	6.75	3.63	4.04	1.60	2.56	N/A	N/A	5.17	N/A
2.750	7.70	3.75	4.06	1.60	2.56	N/A	N/A	5.55	N/A
2.875	7.83	3.88	4.18	1.60	2.56	N/A	N/A	5.62	N/A
3.000	7.94	4.00	4.46	1.74	2.63	N/A	N/A	5.77	N/A
3.125	7.99	4.13	4.60	1.75	2.69	N/A	N/A	5.92	N/A
3.250	8.19	4.25	4.60	1.80	2.64	N/A	N/A	6.05	N/A
3.375	8.30	4.38	4.85	1.94	2.69	N/A	N/A	6.14	6.27
3.500	8.44	4.50	4.97	1.91	2.69	N/A	N/A	6.31	6.43
3.625	8.49	4.63	5.10	2.19	2.69	N/A	N/A	6.44	N/A
3.750	8.75	4.78	5.19	2.00	2.69	N/A	N/A	6.77	N/A
3.875	8.84	4.96	5.37	2.06	2.69	N/A	N/A	6.64	6.77
4.000	9.00	5.11	5.50	2.38	2.69	N/A	N/A	6.78	6.91

TABLE S6 Split Mechanical Seals

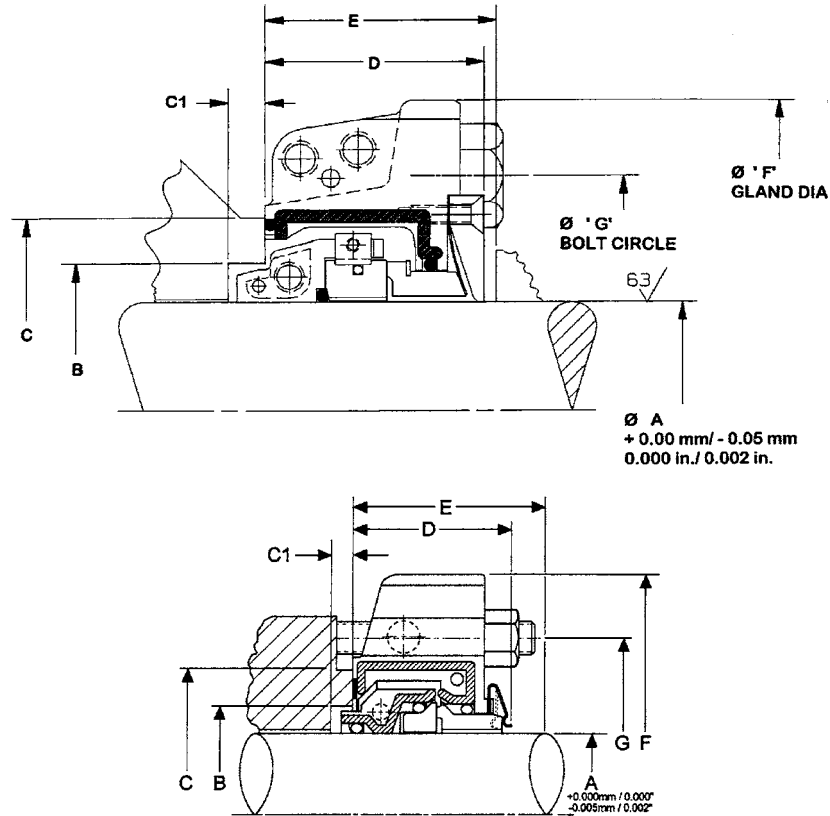

Maximum Dimensions for Seal Interface

A Shaft Diameter	B Box Bore min	B Box Bore max	C Box Face min	C1 Box Depth min	D Outboard Space Required	E Nearest Obstruction	F Gland Diameter	G Bolt Circle min Bolt Size 3/8 in.	G Bolt Circle min Bolt Size 1/2 in.	G Bolt Circle min Bolt Size 5/8 in.
1.250	1.86	2.10	2.35	N/A	1.78	3.00	4.91	3.17	3.29	3.42
1.375	1.94	2.38	2.63	N/A	1.78	3.00	5.01	3.25	3.38	3.50
1.500	2.50	2.50	2.94	0.407	1.88	3.00	5.28	3.68	3.81	3.93
1.625	2.50	2.62	2.94	0.407	1.88	3.00	5.28	3.68	3.81	3.93
1.750	2.50	2.68	3.00	0.407	1.87	3.00	5.28	3.68	3.81	3.93
1.875	2.63	2.87	3.12	0.423	2.00	3.06	5.50	3.78	3.91	4.03
2.000	2.75	3.00	3.31	0.438	2.00	3.06	5.63	3.88	4.00	4.12
2.125	2.87	3.12	3.62	0.313	2.19	3.50	6.13	4.37	4.50	4.62
2.250	3.06	3.25	4.00	0.375	2.25	3.50	6.50	4.56	4.68	4.81
2.375	3.18	3.37	4.12	0.375	2.15	3.50	6.50	4.56	4.68	4.81
2.500	3.18	3.62	4.00	0.375	2.15	3.50	6.50	4.63	4.68	4.87
2.625	3.62	3.87	4.75	0.281	2.38	3.62	7.76	5.38	5.50	5.63
2.750	3.62	4.25	4.75	0.375	2.38	3.62	7.76	5.38	5.50	5.63
2.875	3.93	4.12	5.00	0.375	2.50	3.75	8.01	5.73	5.86	5.98
3.000	3.93	4.12	5.00	0.375	2.50	3.75	8.01	5.74	5.87	5.99
3.125	4.31	4.75	5.25	0.375	2.50	3.75	8.26	5.88	5.86	6.13
3.250	4.31	4.75	5.25	0.375	2.50	3.75	8.50	5.88	5.87	6.13
3.375	4.43	5.00	5.50	0.501	2.50	4.02	8.51	6.18	6.31	6.43
3.500	4.43	5.00	5.50	0.501	2.50	4.02	8.51	6.18	6.31	6.43
3.625	4.75	5.12	5.75	0.407	2.53	4.02	9.00	6.56	6.68	6.81
3.750	4.75	5.12	5.75	0.407	2.53	4.02	9.00	6.56	6.68	6.81
3.875	4.93	5.50	6.00	0.482	2.63	4.02	9.02	6.63	6.75	6.88
4.000	5.00	5.50	6.00	0.407	2.50	4.02	9.02	6.63	6.75	6.88
4.125	5.12	5.71	6.25	0.407	2.50	4.02	9.27	6.86	7.00	7.13
4.250	5.25	5.75	6.25	0.407	2.50	4.02	9.27	6.86	7.00	7.13
4.375	5.42	6.00	6.50	0.457	2.50	4.02	9.55	7.13	7.25	7.38
4.500	5.42	6.12	6.50	0.457	2.50	4.02	9.55	7.13	7.25	7.38
4.625	5.35	6.12	6.75	0.457	2.50	4.02	9.77	7.38	7.50	7.63
4.750	5.62	6.12	6.75	0.432	2.50	4.02	9.77	7.38	7.50	7.63

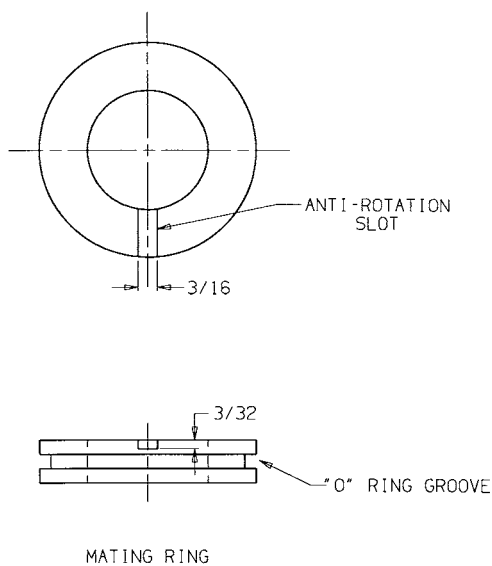

NOTE 1—For shaft sizes less than 1 in., not including 1 in. The anti-rotation slot is not required.

FIG. S1 Standard Mating Ring Anti-Rotation Slot Detail

S5.10.1 Sectional assembly drawings shall include a sectional assembly with references to a parts list identifying materials for all individual parts.

S5.10.1.1 All running clearances shall be shown and shall be dimensioned and labeled as diametral clearances.

S5.10.1.2 Tightening torques with tolerances and thread lubrication requirements for threaded fasteners shall be shown on the drawing.

S5.10.1.3 Assembly drawings shall show, as a minimum, the dimensions shown on the applicable Tables S1-S4.

S5.10.1.4 Drawings shall specify the type, amount, and required use of lubricant.

S5.10.1.5 Drawings shall specify where there is an adhesive or other setting compound factory installed on the elastomer bellows or O-ring that seals between the mechanical seal and the impeller hub, shaft, or shaft sleeve.

S5.10.1.6 Drawings shall provide a description of any adhesive or setting compound identified in S5.10.1.5 including any time limits associated with the compound when present on a mechanical seal in storage and between initial wetting of that compound and the final positioning of the mechanical seal in the pump.

S5.10.2 When requesting qualification testing to satisfy Tables S1—S6, component drawings shall be submitted to NAVSEA for review and approval. Drawings to include dimensional details, manufacturing tolerances, and material specifications. Seal drawings to be used for NAVSEA verification only.

S5.10.3 Shock requirements are specified under Section S7.8 Shock Test.

S5.11 “J-seat” stationary ring designs shall be allowed for lube oil and fuel oil services.

S6. Materials

S6.1 The mechanical seal metal parts shall be supplied in accordance with Table S7.

S6.2 The primary seal ring shall be carbon-graphite,⁸ silicon carbide, or 6 to 10 % nickel-bound tungsten carbide. The mating ring face shall be 6 to 10 % nickel-bound tungsten carbide or silicon carbide and suitable for the liquid being pumped. Cobalt-bound tungsten carbide shall not be used. Nodular or graphitic ductile nickel cast iron,⁹ may be supplied for lubricants and fuel oil service.

S6.3 Elastomers such as bellows, O-rings, friction rings, and so forth, furnished with seals supplied to the requirements of this Supplement S1 shall be made of fluorocarbon elastomer in accordance with MIL-R-83248, CL 1 or CL 2, or Practice D 1418 Class FKM, unless otherwise specified in the contract. Refer to Table 3 for general service applications and for alternative elastomers suitable for special requirements.

S6.4 On seawater pumps, the mechanical seal O-rings and other elastomers shall not be mounted on or come in contact with the impeller.

S6.5 All mechanical seals under this specification shall be certified to be free of functional mercury.

S7. Testing of Mechanical Seals

S7.1 The purpose of these test procedures is to develop a high confidence level that a Class 0 mechanical seal has a projected statistical life of 16 000 h under normal field service conditions.

S7.2 To qualify a mechanical seal design, NAVSEA¹⁰ will first conduct a technical evaluation, reviewing the manufacturer’s design for compliance with this specification, configuration, material and performance requirements. Subsequent to technical evaluation, the seal will undergo a performance evaluation, including:

	<i>Test</i>
Run-in—8 h	
Hydrostatic—5 min	
Operational—500 h	
Shock—Mil-S-901 (Grade A)	
	<i>Parameters Monitored/Measured</i>
Operating pressure	
Operating temperature	
Surface speed (ft/min)	
Fluid media	
Leakage rate	
Wear rate	

S7.2.1 Testing, including qualification testing, of Classes 1 through 4 split mechanical seals shall be application specific,

⁸ Carbon graphite material shall be a manufacturer’s grade that has been tested and qualified for mechanical seal face service under the qualification tests required by this specification and has been documented as being in regular shipboard service under equivalent operating conditions.

S6 Split Seals shall use carbon graphite grades CTI-6 or P8412. Alternative carbon graphite materials will be conditionally approved by NAVSEA for specific mechanical seal service. Approval for general service will be granted after seal qualification testing under this specification and after evidence of satisfactory shipboard service under equivalent operating conditions, is provided.

⁹ Ni-Resist (term and logo copyright Dura-Bar, 2100 West Lake Shore Drive Woodstock, IL 60098) or equivalent has been found satisfactory for this purpose.

¹⁰ Department of the Navy, Naval Sea Systems Command, NAVSEA, Arlington, VA 22242-5160.

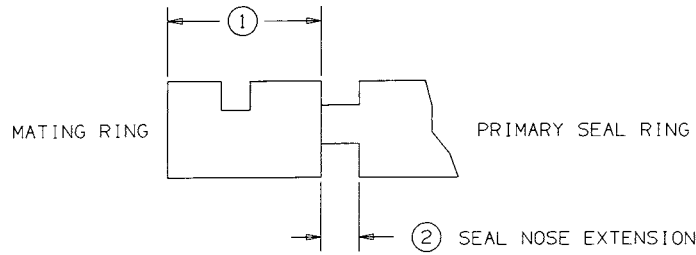

NOTE 1. MEASURE ① AT THE FACE CONTACT SURFACE

	①		②
PRE RUN PR		X	
POST RUN PO		X	
MATING RING WEAR PR - PO		PRIMARY SEAL RING WEAR PR - PO	

$$\frac{\text{MATING RING WEAR} + \text{PRIMARY SEAL WEAR}}{\text{HOURS OF RUNTIME}} = \text{WEAR RATE} \text{ INCH/HR}$$

$$\frac{\text{PR } ②}{\text{WEAR RATE}} = \text{HOURS OF SEAL LIFE}$$

FIG. S2 Dimensional Record

conducted under test conditions, which include the proposed operating conditions, and under a test schedule and performance requirements that have been agreed upon by the purchaser (buyer) and the manufacturer.

S7.2.2 Type E seals shall be tested with 0.035 in. of axial endplay towards the driver end of the pump.

S7.2.2.1 Test to be accomplished using a fluid with a viscosity of 100-500 SSU at start-up. Air shall be used as the barrier fluid.

S7.2.2.2 Run-In Test:

(a) Run-in test specified below per sections S7.2.2.2, S7.2.2.3, and S7.2.2.4 is based on a 1.750-in. shaft size for lube and fuel oil pumps. Type E seals greater than 1.750 in. shaft size shall have an air consumption rate less than or equal to 0.2 % of rated pump capacity.

(b) Run-in test shall be accomplished for 8 h at a speed of 800 fpm with a fluid pressure of 5 psig and a barrier pressure of 125 psig. Zero fluid leakage is required during this test. Air consumption rate shall be less than or equal to 1.90 nl/min or 4.0 scfh.

(c) Seal shall be operated for 20 min with conditions as above except the speed shall be 300 fpm. Fluid leakage and air consumption shall meet requirements of S7.2.2.2.

S7.2.2.3 The 500 h endurance test for Type E seals shall be accomplished by performing 125 h of testing at each of the following conditions:

- 800 fpm, 65 psig fluid pressure, 80 psig barrier pressure
- 300 fpm, 65 psig fluid pressure, 80 psig barrier pressure
- 800 fpm, 5 psig fluid pressure, 125 psig barrier pressure
- 300 fpm, 5 psig fluid pressure, 125 psig barrier pressure

(a) A total minimum of 25 starts and stops must be performed during the endurance testing. Each start cycle must include a minimum of 5 min of operating time. A minimum of three 8-h rest periods must be taken during the endurance test.

(b) During endurance testing, there shall be no visible fluid leakage. Maximum barrier consumption rate shall be 1.90 nl/min or 4.0 scfh.

S7.2.2.4 Type E seals shall undergo a seal recovery test. Test shall be performed in the following order:

- (1) 15 min at 300 fpm, 65 psig fluid pressure, 125 psig barrier pressure
- (2) 15 min at 300 fpm, 65 psig fluid pressure, disconnect air source, vent to atmosphere
- (3) 15 min at 800 fpm, 100 psig fluid pressure, 125 psig barrier pressure
- (4) 15 min at 800 fpm, 100 psig fluid pressure, disconnect air source, vent to atmosphere
- (5) 15 min at 300 fpm, 65 psig fluid pressure, 125 psig barrier pressure

At the end of the recovery test, there shall be no visible fluid leakage. Maximum barrier consumption rate shall be 1.90 nl/min or 4.0 scfh.

S7.2.3 Any changes to a qualified mechanical seal shall be presented to the government buying activity for technical evaluation.

TABLE S7 Material Requirements and Service Limits for Standard Seals^A

Fluid		Fuels and Lubricants	Fresh Water	Fuels/Seawater
Design Detail				
Metal components (TRIM) ^B		316 stainless steel NiCu Alloy 20 bronze ^C		NiCu titanium Alloy 20 bronze ^C NiCrMoCo
Springs ^D		316 stainless steel NiCu NiCrFe NiMo NiCrMoCo NiMo (Alloy B) NiMo (Alloy C) NiCr NiCrMoCb		NiCu NiCrFe NiMo NiCrMoCo NiMo (Alloy B) NiMo (Alloy C) NiCr NiCrMoCb
Elastomer components		fluorocarbon ^{EF} elastomers		
Primary seal ring		carbon graphite ^G		
Mating ring		Nodular or graphitic ductile nickel cast iron Tungsten carbide (6 to 10 % nickel bond) Silicon carbide	Tungsten carbide ^H (6 to 10 % nickel bound) Silicon carbide	
Pressure		150 psig max (1.03 MPa)		
rpm Max	Tables S1 and S2	3600 rpm		
	Tables S3 and S4	1800 rpm		
Temperature		225°F (107°C) max	170°F (77°C)	

^A See Tables S1-S4 for standard seal envelopes and Section 6 for application material specification.
^B Drive set screws not applicable and shall be of harder material than the shaft.
^C Older design seals in service, replacement parts, and assemblies only.
^D Wave spring materials may be supplied to "chemistry only" limits of the material specification.
^E See Table 3 for elastomer compatibility.
^F Ethylene propylene may be used where specified for special purposes.
^G See Footnote 6 for acceptable grades and approval requirements.
^H See Table 2 for performance limits of face material combinations.

TABLE S8 Qualification Test Parameters

Mechanical Seal Type	Test Sequence	Axial Offset ^A ±0.003 in. (0.08 mm)	Radial Offset ±0.003 in (0.08 mm)	Test Sequence Duration
Tables S1 and S2	Run-in 0	0 0	0 20 min	8 h
	Performance tests	+(0.035 in. (0.89 mm) + SNE) ^B 20 h 20 h 20 h 20 h 400 h	0	20 h
Tables S3 and S4	Run-in 0	0 0	0 20 min	8 h
	+(0.030 in. (0.76 mm) + SNE) ^B 0	0 20 h	20 h	
	0.010 in. (0.25 mm)	20 h		
	0.010 in. (0.25 mm)	20 h		
	0.010 in. (0.25mm) 0	20 h 400 h		

^A 0 = neutral position.
^B SNE = seal nose extension—Ref. Fig. S3.

7.3 General Comments:

7.3.1 Data will be collected and entered on data sheets similar to those in Fig. S2 and Fig. S3.

7.3.2 Any problems encountered with the seals, installation, operation of the test fixture, or breakdowns of any kind,

shall be recorded. This record shall include a statement of the problem, cause, running time meter reading at occurrence, and any other pertinent information.

7.3.3 All tests shall be performed in sea water using the same seal.

TEST FACILITY: _____

SEAL MANUFACTURER _____ PART NO. _____

SEAL SIZE _____

START NO.	DATE	TIME	RUN TIME	PRES (PSIG)	TEMP (°F)	RPM	LEAK RATE cc/min

DATE _____

TECHNICIAN SIGNATURE _____

ENGINEERS SIGNATURE _____

FIG. S3 Mechanical Seal Test Data Sheet

S7.3.4 The test conditions shall be:

- Speed: 3600 rpm $\pm 5\%$ [Tables S1 and S2](#)
- 1800 rpm $\pm 5\%$ [Tables S3 and S4](#)
- Temperature: 170°F (77°C), monitored at seal cavity. The flowrate shall be varied as necessary to maintain the seal cavity at the specified temperature.
- Pressure: 150 psig (1.03 MPa) ± 5 psi (0.03 MPa)
- Fluid media: ocean water per Specification [D 1141](#)

S7.3.5 Any seal shown in **Table S1** and **Table S2** successfully passing all tests will qualify any smaller seal of the same design up to but not including 1 in. (25.4 mm) smaller.¹¹

S7.3.6 *Test Facility*—The test facility must be approved by NAVSEA before conducting the tests. Approval criteria will be based on information submitted by the facility demonstrating the capability to perform all tests indicated herein.

S7.4 Pretest Inspection:

S7.4.1 The seal shall be photographed as received from the manufacturer and examined for compliance. The mating surfaces shall be photographed to document the original unworn condition. All critical dimensions shall be measured and recorded. The width of the stationary mating ring and the height of the rotating primary seal nose shall be measured at 60° intervals. A reference point for these measurements shall be established to ensure that the posttest measurements are taken at identical locations. If a seal face is not measurable as an individual component, the manufacturer must provide the information with photographs and certify the critical dimensions to 0.0001 in. (2.5 mm). Acceptance criteria: seal face wear rate must allow for an extrapolated service life of 16 000 h.

S7.4.2 The seal shall be examined for the following defects:

- S7.4.2.1 Components missing or not as specified,
- S7.4.2.2 Dimensions not as specified,
- S7.4.2.3 Materials not as specified,
- S7.4.2.4 Assembly incorrect,
- S7.4.2.5 Workmanship not as specified, and
- S7.4.2.6 Configuration not in conformance with drawing.

S7.5 *Run-In Test*—After completion of the pretest inspection and seal installation, the test fixture shall be stabilized at the temperature, pressure, and speed specified for the test which shall be conducted immediately after the run-in test. The seal shall be operated for a period of 8 h continuously at test conditions and stopped. All the area on the test fixture that would collect fluid escaping past the seal shall be wiped clean and dry. The seal shall then be operated at the same test conditions for 20 min after which the leakage will be checked. Acceptance criteria: there shall be no apparent leakage.

S7.6 *Hydrostatic Test*—After successful completion of the prerequisites specified in the previous sections, the seal shall be subjected to 1.5 times the operational test pressure for a period of 5 min. During this test, the motor shall not be operated. Acceptance criteria: there shall be no measurable leakage.

S7.7 Operational Test:

S7.7.1 After successful completion of the hydrostatic test, the seal shall remain in the test fixture for the purpose of conducting the operational test.

S7.7.2 The seal test fixture shall be stabilized at the temperature, pressure, and speed specified. The operational test shall be for a period of 500 h running time with a minimum of 25 starts. Testing will be conducted at the neutral position and with axial and radial offsets, for the duration of the test sequences as listed in **Table S6**.

S7.7.3 During the operational test, the test fixture shall be monitored to record accurately the conditions of operation (pressure, temperature, speed, and so forth). Data shall be collected and the fixture examined at least twice daily. In addition to all measured data, the record shall indicate the seal leakage rate. Acceptance criteria: (1) There shall be no measurable leakage. (2) Seal face wear rate extrapolates to a minimum service life of 16 000 h.

S7.8 Shock Test:

S7.8.1 The governing document for the shock test shall be **MIL-S-901**. The seal test fixture, mounted on the anvil plate of a shock testing machine for lightweight equipment, shall be tested with water and shall be stabilized at room temperature, 30 psig (207 kPa) and 1800 or 3600 rpm. General requirements for the shock test are as follows:

Grade—A
Class—I
Type—C

All mounting and testing shall be performed in accordance with the requirements of **MIL-S-901** pertaining to lightweight shock. Shock tests shall be conducted in the dynamic mode of operation. Seal leakage rate shall be monitored and recorded. Acceptance criteria: mechanical seal leakage rate shall not exceed five drops/min.

S7.8.2 A mechanical seal may also be qualified by testing in a pump unit as per **MIL-S-901**.

S7.9 *Posttest Inspection*—After completion of tests specified in S7.1 to S7.6, the seal shall be removed and all seal components closely examined. Record any unusual details. After removal, the seal shall be disassembled and an internal examination of the seal conducted as specified in S7.2.1. Wear shall be measured at 60° intervals relative to the reference point established during the pretest inspection. Photographs shall be used to document the worn condition of the seal. Average wear rate for the operational test shall be extrapolated to 16 000 h to determine the service life wear requirement. Examine and analyze the data obtained above and compare it to the data collected during the pretest inspection.

S8. Packaging and Marking

S8.1 The packaging and marking requirements specified herein apply only for direct U.S. Government acquisitions.

S8.2 Mechanical seals shall be preserved-packaged level A or C, packed level A, B, or C as specified, and marked in accordance with **MIL-P-16789**. Unless otherwise specified, package in accordance with Practice **D 3951**.

¹¹ Example: Successfully qualifying a 2.000-in. (50.8-mm) diameter seal would likewise qualify all seal sizes from 2.000 to 1.125 in. (50.8 to 28.5 mm).

(Mandatory Information)
A1. TERMINOLOGY: DESCRIPTION OF TERMS RELATING TO MECHANICAL SEALS AND THEIR APPLICATION

A1.1 *balanced seal*—a mechanical seal designed to accommodate high stuffing box pressure with a decrease in seal face closing forces.

A1.2 *barrier fluid*—see buffer fluid.

A1.3 *bellows*—flexing seal elements:

A1.3.1 An elastomeric seal element with a full or half convolution that acts as a flexible secondary seal.

A1.3.2 Formed or welded metal seal element that provides spring load and a flexible secondary seal. See Fig. 1 and Fig. 4.

A1.4 *buffer fluid*—a lubricating liquid which is introduced between two seal assemblies to provide protection to the seal and/or the environment.

A1.5 *bushing*—a device used to restrict flow. See Fig. 1.

A1.6 *cartridge seal*—a completely self-contained assembly including seal, gland, sleeve, and drive collar or seal assembly & which can be assembled on to a pump as one unit.

A1.7 *centrifugal separator*—a device using centrifugal force to remove solids in a seal flushing liquid.

A1.8 *diametral clearance*—the difference between the diameters of two parts.

A1.9 *double seal*—two mechanical seals mounted back to back, or face to face, designed to contain a buffer fluid between the two seals. See Figs. 4-6.

A1.10 *elastomer drive seal*—a mechanical seal in which rotation of the seal assembly is accomplished through an elastomeric secondary seal.

A1.11 *end play*—movement along the axis or parallel to the center line of a shaft.

A1.12 *end face seal*—a mechanical seal that prevents leakage of fluids. Sealing is accomplished by means of a stationary seal ring bearing against the face of a rotating ring mounted on a shaft. Primary sealing is accomplished in a plane *perpendicular* to the shaft axis.

A1.13 *flush*—liquid that is introduced into the seal chamber in close proximity to the sealing faces.

A1.14 *gland gasket*—a static seal used between the gland plate and the pump casing.

A1.15 *gland plate*—a pressure-containing housing that is attached to the pump casing and holds the stationary part of the seal.

A1.16 *gland plate, solid*—a gland plate, according to A1.15, whose pressure retaining member is not radially split.

A1.17 *gland plate, split*—a gland plate that is split on a plane parallel to the axis of the shaft, with the result that the gland can be assembled around the shaft without requiring access over the end of the shaft.

A1.18 *inside mounted seal*—a mechanical seal assembly mounted inside the cavity which holds the fluid to be sealed.

A1.19 *light bands*—the horizontal distance between corresponding dark fringes on a reflective objective reference when viewed through an optical flat exposed to a monochromatic light source. For flatness measurement, the distance from one dark fringe to the next is 11.566 μm . for a helium gas light.

A1.20 *mating ring*—a precision lapped seal face normally mounted in a gland plate.

A1.21 *noncontacting seal*—a seal where the mating faces are designed to intentionally create an aerodynamic or hydrodynamic separating force to sustain a separation gap.

A1.22 *nonpusher seal*—a mechanical seal in which seal wear and end-play are compensated for by flexing a secondary seal element.

A1.23 *operating length*—the axial distance from the seal face to a reference plane. Also referred to as seal working height.

A1.24 *outside mounted seal*—a mechanical seal assembly mounted outside the cavity which holds the fluid to be sealed.

A1.25 *packing*—materials fitted into a stuffing box and compressed to form a seal between the shaft and the stuffing box bore.

A1.26 *positive drive*—mechanical means of providing rotational torque in a rotating seal element or preventing rotation in a stationary seal element by use of pins, tabs, keys, or set screws.

A1.27 *primary seal ring*—a precision lapped seal face which is held in the seal assembly.

A1.28 *pumping ring*—a simplified impeller within the seal cavity which circulates liquid for cooling.

A1.29 *pusher seal*—a mechanical seal with a dynamic secondary seal element.

A1.30 *quench*—a fluid that is introduced on the atmospheric side of the seal. Quench fluid is introduced through ports in the gland plate.

A1.31 *rotating seal*—a seal assembly in which the primary spring mechanism is rotated with the shaft.

A1.32 *seal cavity*—the space within a pump housing or gland between a stuffing box bore and a shaft in which a seal is installed.

A1.33 *seal nose*—the axial projection on the primary seal ring of an end face seal which forms the sealing surface.

A1.34 *secondary seal*—a device which provides dynamic sealing between the rotating element of a mechanical seal assembly and the shaft or sleeve. See **Figs. 1 and 6**.

A1.35 *shaft run-out*—twice the distance by which the center of the shaft is displaced from the axis of rotation.

A1.36 *shaft sleeve*—a cylinder placed over a shaft to provide protection of the shaft from wear and corrosion. It may be used to provide spacing for the impeller and as a device to provide a step in the shaft to achieve seal balance and/or positioning.

A1.37 *sleeve gasket*—a static seal used to prevent leakage between the shaft and the sleeve.

A1.38 *split seal*—a mechanical seal that has its elements split in a plane parallel to the axis of the shaft, with the result that instead of being continuous rings, they are essentially two semicircles.

A1.39 *split seal, partial*—a split mechanical seal in which only the rotating and stationary sealing face components and

packing elements are split and replaceable by assembly around the shaft.

A1.40 *split seal, fully*—a split mechanical seal in which all of the rotating and stationary seal components are split, allowing the entire seal to be assembled around the shaft without requiring access over the end of the shaft.

A1.41 *static seal*—a seal between surfaces which have no relative motion.

A1.42 *stationary seal*—a seal assembly in which the primary spring mechanism does not rotate.

A1.43 *stuffing box pressure*—operating pressure for the mechanical seal.

A1.44 *tandem seal*—a multiple seal arrangement consisting of two seals mounted one after the other, with the faces of the seal assemblies oriented in the same direction. See **Fig. 6**.

A1.45 *throat bushing*—a bushing mounted at the bottom of the stuffing box that restricts flow into or out of the seal cavity. (See *bushing*.)

A1.46 *throttle bushing*—a bushing mounted in the gland to restrict flow of seal leakage or quench fluid to atmosphere. (See *bushing*.)

A1.47 *unbalanced seal*—a seal in which the total hydraulic pressure in the seal cavity acts on the faces of the mechanical seal.

APPENDIXES

(Nonmandatory Information)

X1. SEAL ASSEMBLY INSTALLATION INSTRUCTIONS

X1.1 *Before Installation of Seal:*

X1.1.1 Review the seal manufacturer's installation drawings or instructions, or both.

X1.1.2 Verify proper equipment interface requirements as per 8.3.

X1.1.3 Keep the seal assembly clean and protected, especially the faces. If faces contain protective covering, leave the covering on until the last possible moment. If the rotary or stationary units must be touched, always cover the faces with a clean dry cloth.

X1.1.4 Check the secondary seals. Certain types require special lubricants or preparation before the placement in the equipment. PTFE wedges, V-, O-rings, and TFE-encapsulated O-rings may require special treatment before placement on shaft or in groove.

X1.2 *Seal Assembly Installation Procedures*—For cartridge or split seal designs, consult specific manufacturer's installation instructions.

X1.2.1 Remove any loose matter in stuffing box and stationary cavity in gland plate with a cloth. Wipe these areas clean.

X1.2.2 Remove all burrs and sharp edges on shaft.

X1.2.3 Wipe shaft clean with a dry clean cloth.

X1.2.4 Lubricate the shaft and secondary seal.

X1.2.5 Elastomeric driven seals require the shaft to be lubricated with water or a very light grade oil. A nongranulated waterless soap is recommended. (**Warning**—Do not use petroleum jelly, TFE (tetrafluoroethylene), or silicone grease on an elastomer driven seal. EPR (ethylene propylene rubber) must not be lubricated with any petroleum base substance.)

X1.3 *Installing the Mating Ring:*

X1.3.1 Check to make sure that the cavity for the mating ring is clean and free of all foreign matter.

X1.3.2 Lubricate the mating ring static seal as in Paragraph **X1.2.5**.

X1.3.3 Carefully install mating ring by pressing it into the gland plate counterbore until it is bottomed and square.

X1.4 *Installation of the Seal and Mating Ring Assembly:*

X1.4.1 Slide the seal assembly on to the pump shaft. Make certain that it is properly positioned in relationship to the stuffing box and shaft. If set screws are used, verify installation reference to face of stuffing box. Tighten set screws.

X1.4.2 Before setting the seal compression, carefully and lightly wipe seal faces with a lint free cloth or remove face protective coverings.

X1.4.3 Install gland plate gasket.

X1.4.4 Bring gland plate into position and bolt it to the stuffing box face. (**Warning**—Excessive tightening of gland plate bolts could result in distortion and damage to the gland or the seal faces, or both.)

X1.5 *Reassemble the Pump.*

X2. PART NUMBERING SYSTEM

X2.1 Part numbers for mechanical seals shall include the number of this specification followed by a letter for the seal type and nine numerals to signify the grade, class, dimensions, metal component material, spring material, primary seal ring and mating ring material combinations, and elastomer component material. An example of this system is:

F1511 A 1 0 122 2 2 2 1

Docu- ment identi- fier	Type	Grade	Class	Dimen- sions	Metal compo- nent material	Spring material	Primary seal ring and mating ring ma- terials	Elastomer compo- nent material
----------------------------------	------	-------	-------	-----------------	-------------------------------------	--------------------	--	---

X2.1.1 *Type:*

X2.1.1.1 A—Inside single mounted seals (4.1.1)

X2.1.1.2 B—Outside single mounted seals (4.1.2)

X2.1.1.3 C—Double seals (4.1.3)

X2.1.1.4 D—Tandem seals (6.2.1)

X2.1.1.5 E—Special arrangements/applications vacuum or gas seal (4.1.6)

X2.1.2 *Grade:*

X2.1.2.1 1—Basic end face seal (4.1.7)

X2.1.2.2 2—Cartridge seal (4.1.8)

X2.1.2.3 3—Split seal (4.1.9)

X2.1.3 *Class:*

X2.1.3.1 0—All nonsplit seals (Grades 1 and 2) (4.1.10)

X2.1.3.2 1—Partial split seal assembly, solid gland (4.1.11)

X2.1.3.3 2—Partial split seal assembly, split gland (4.1.12)

X2.1.3.4 3—Fully split seal assembly, solid gland (4.1.13)

X2.1.3.5 4—Fully split seal assembly, split gland (4.1.14)

X2.1.4 *Seal Dimensions:*

X2.1.4.1 001 through 030—Commercial sizes starting at 0.375 in. and increasing in 0.125-in. size intervals to 4000 in.

X2.1.4.2 101 through 130—Standard long mechanical seal (Table S1)

X2.1.4.3 201 through 230—Standard short mechanical seal (Table S2)

X2.1.4.4 301 through 304—Special cartridge seals Grade 2 (Table S3)

X2.1.4.5 401 through 405—Special seals Grade 1 (Table S4)

X2.1.5 *Metal Component Material (Table 1 and Table S5):*

X2.1.5.1 1—316 stainless steel

X2.1.5.2 2—NiCu, Alloy 20 or bronze

X2.1.5.3 3—Titanium

X2.1.5.4 4—Copper alloy

X2.1.5.5 5—Highly alloyed stainless steel, NiMo, NiCr-MoCb or NiCrFe

X2.1.5.6 6—Special material

X2.1.6 *Spring Material (Table 1 and Table S5):*

X2.1.6.1 1—316 stainless steel

X2.1.6.2 2—NiCu, NiCr, NiCrMoCb, NiMo, NiMo (Alloy B), NiMo (Alloy C), NiCrFe, or NiCrMoCo

X2.1.6.3 3—Special material

X2.1.7 *Primary Seal Ring Material and Mating Ring Material Combinations (Table 2 and Table S5):*

X2.1.7.1 1—Carbon graphite and nodular or graphitic ductile nickel cast iron

X2.1.7.2 2—Carbon graphite and tungsten carbide

X2.1.7.3 3—Carbon graphite and silicon carbide

X2.1.7.4 4—Siliconized carbon and tungsten carbide

X2.1.7.5 5—Siliconized carbon and silicon carbide

X2.1.7.6 6—Silicon carbide and tungsten carbide

X2.1.7.7 7—Silicon carbide and silicon carbide

X2.1.7.8 8—Tungsten carbide and tungsten carbide

X2.1.7.9 9—Special materials

X2.1.8 *Elastomer Component Material (Table 3 and Table S5):*

X2.1.8.1 1—Fluorocarbon

X2.1.8.2 2—Ethylene propylene

X2.1.8.3 3—Nitrile

X2.1.8.4 4—PTFE

X2.1.8.5 5—Corrugated graphite ribbon

X2.1.8.6 6—Chloroprene

X2.1.8.7 7—Special material

ASTM International takes no position respecting the validity of any patent rights asserted in connection with any item mentioned in this standard. Users of this standard are expressly advised that determination of the validity of any such patent rights, and the risk of infringement of such rights, are entirely their own responsibility.

This standard is subject to revision at any time by the responsible technical committee and must be reviewed every five years and if not revised, either reapproved or withdrawn. Your comments are invited either for revision of this standard or for additional standards and should be addressed to ASTM International Headquarters. Your comments will receive careful consideration at a meeting of the responsible technical committee, which you may attend. If you feel that your comments have not received a fair hearing you should make your views known to the ASTM Committee on Standards, at the address shown below.

This standard is copyrighted by ASTM International, 100 Barr Harbor Drive, PO Box C700, West Conshohocken, PA 19428-2959, United States. Individual reprints (single or multiple copies) of this standard may be obtained by contacting ASTM at the above address or at 610-832-9585 (phone), 610-832-9555 (fax), or service@astm.org (e-mail); or through the ASTM website (www.astm.org).